

ELECTRONIC  GEEK.CA

Assembly manual V1.6
Prusa i3 EG-1(+)

Classification Of Screws



M3 nuts 60pcs



M8 nuts 12pcs



M8 Cushion ring
12pcs



M3*20mm Round head
screws 58pcs



M3*10mm inner
hexagon screws 17pcs



M3*14mm Flat-head
screws 4pcs



M2.5*10mm black
screws 2pcs



M3*30mm Flat-head
screws 7pcs



Plastic Pillars 4pcs

Classification Of Screws



M3*30mm Flat head
screws 4pcs



M4*15mm Round head
cross screws 12pcs



Thumb nuts*4



Compression springs*4



M3*20mm Round head
screws 4pcs

Pre Assembly Preparations

Take out the bag of screws and nuts and scatter them on your assembly table, by size and type, like the picture below.

This will help you assemble more rapidly the printer, you won't search the parts to much



Pre Assembly Preparations(suite)

Now, you can unwrap the Lexan parts from it's protective paper.

Like the picture shows below. And scatter the parts for the build to see if something is missing!

If you leave it there, it's not a big deal, but it will be harder to remove when the printer is all assembled!!!

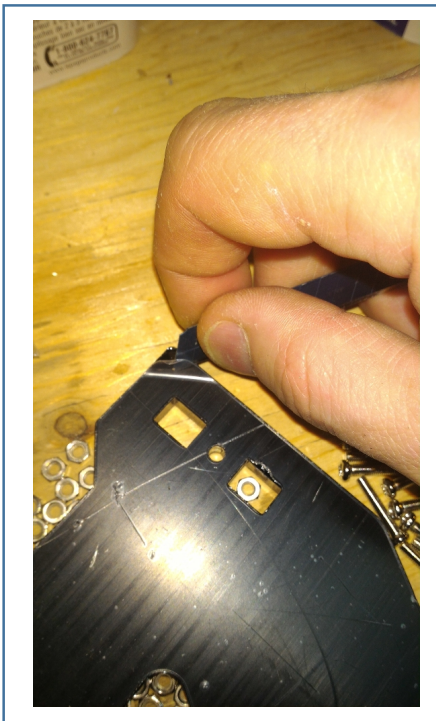

Step 1 Assemble Y-axis Motor

Fit the synchronous pulley on the motor, Locking it with **M3*2mm jackscrew**.

As shown, Put Y-axis motor on **<Y-axis motor support>** , locking with Four **M3*10mm screws**.

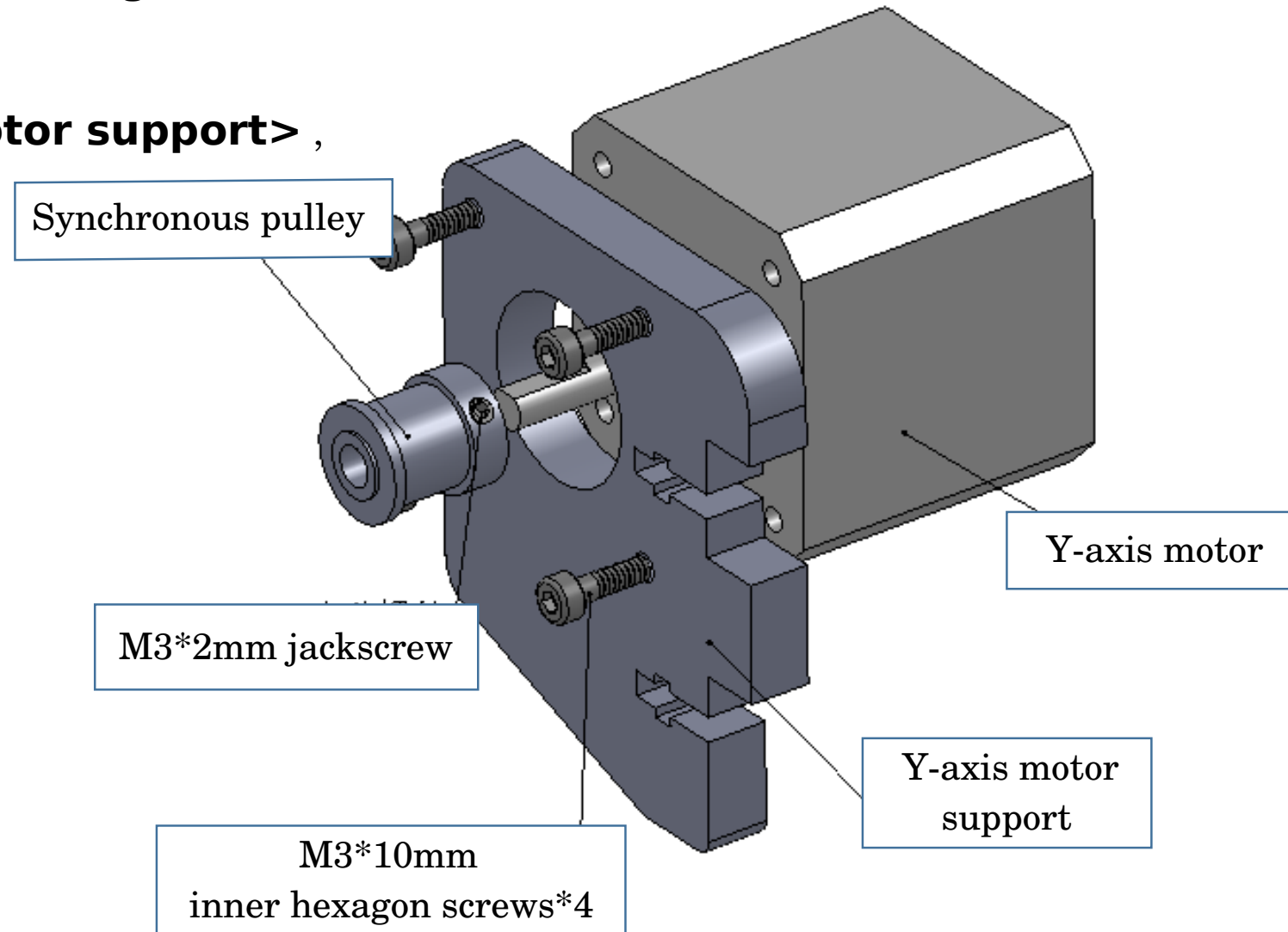

Step 2 Assemble Y-axis Limit switch

Put the **Y-axis limit switch** and the **holder** together ,locking with two **M3*20mm Round head screws & nuts**. As shown

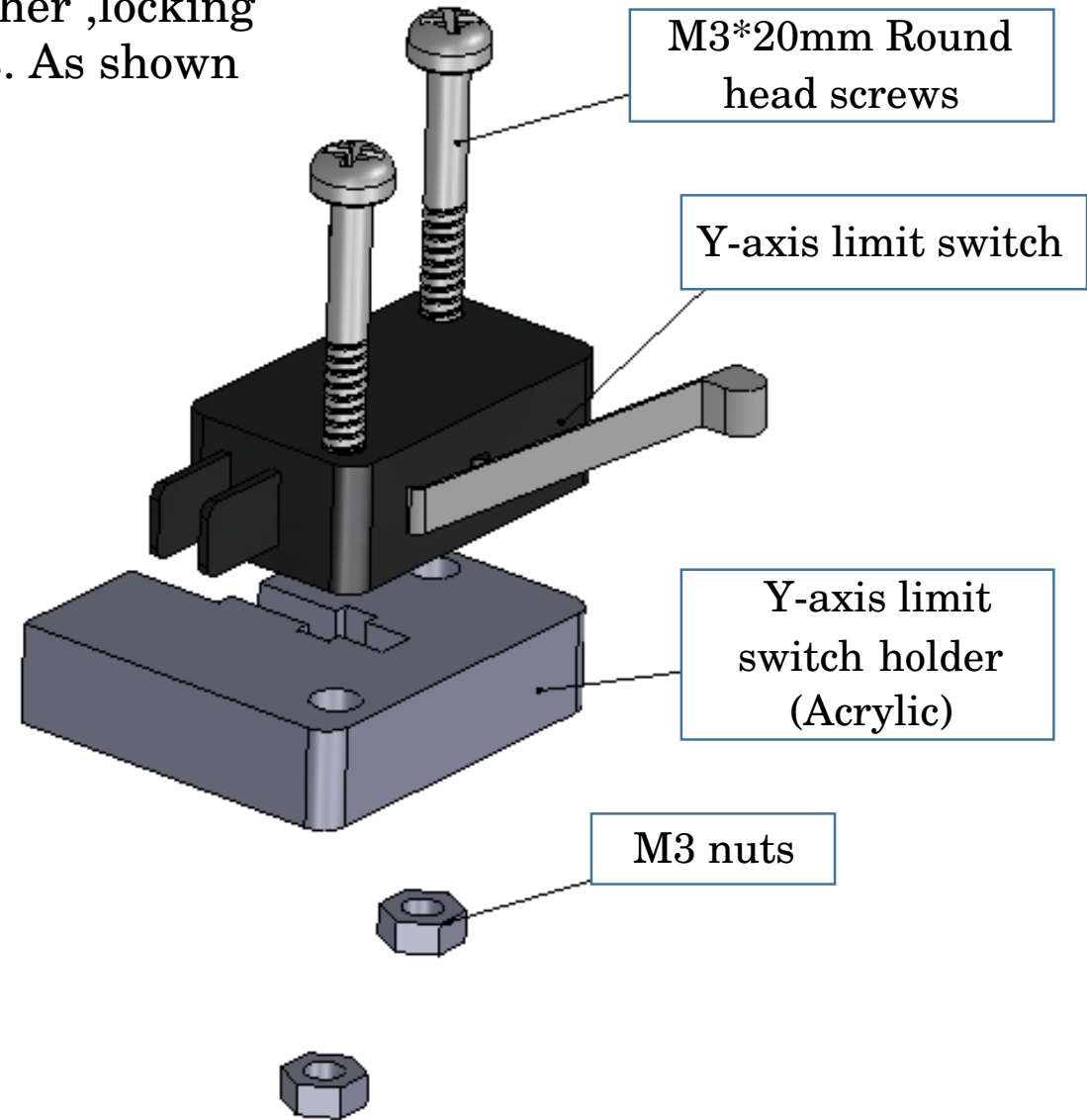

Step 3 Assemble Base Frame Holder_Back

As shown, put two of the **Sliding rod Restriction** in front of the **base frame holder (back)**. locking with two **M3*20mm Round head screws & nuts**.

Put the limit switch and holder assembly on the base frame holder, locking with one **M3*20mm Round head screw & nut**.

Put **Y-axis motor holder** on base frame holder ,locking with **one M3*20mm Round head screw & nut**.

Put Y-axis motor assembly on base frame holder, locking with **three M3*20mm Round head screws & nuts**.

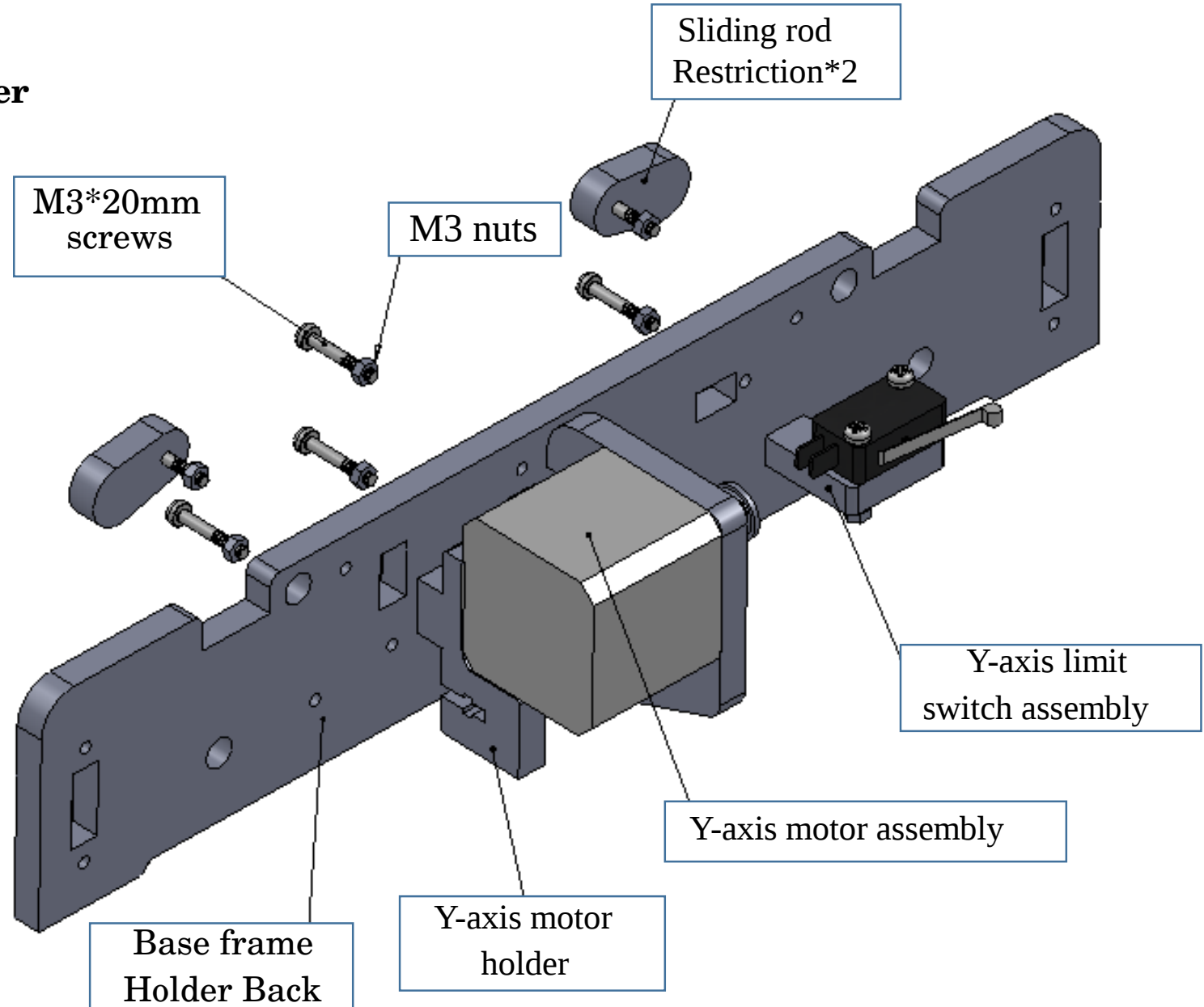

Step 4 Assemble Base Frame Holder_Front

As shown, put two of the **Sliding rod Restriction** in front of the base frame front holder . Locking with two **M3*20mm Round head screws & nuts**.

Put Y-axis belt pulley wheel assembly behind the base frame holder, Locking with two **M3*20mm Round head screws & nuts**.

Do not screw the belt pulley completely. Later when installing the Y axis belt, you will use it to adjust the belt tension.

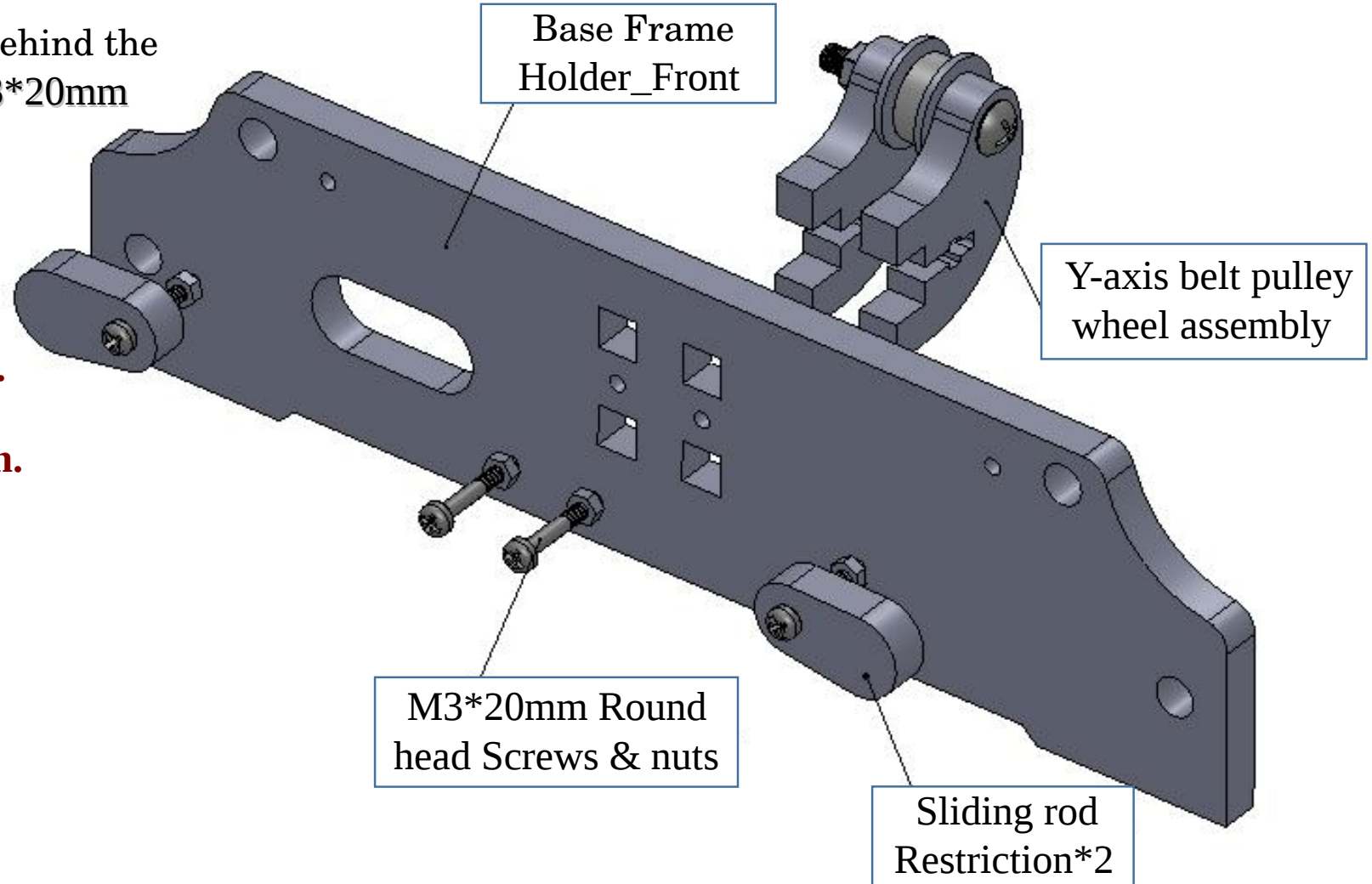

Step 5 Assemble Heat Bed Frame (Already Assembled only for references)

Firstly fixed the Bed Frame and M3 nuts fixed parts together with **M3*20mm**. As picture below.

As shown, put Aluminium plate and heat bed together, locking with **four M3*30mm screws & nuts**.

Put **three bearings** under the bed frame, locking with **twelve M4*15 Round head cross screws**.

Put four compression spring between heat bed and the bed frame. Next **Top four thumb nuts** under the bed frame

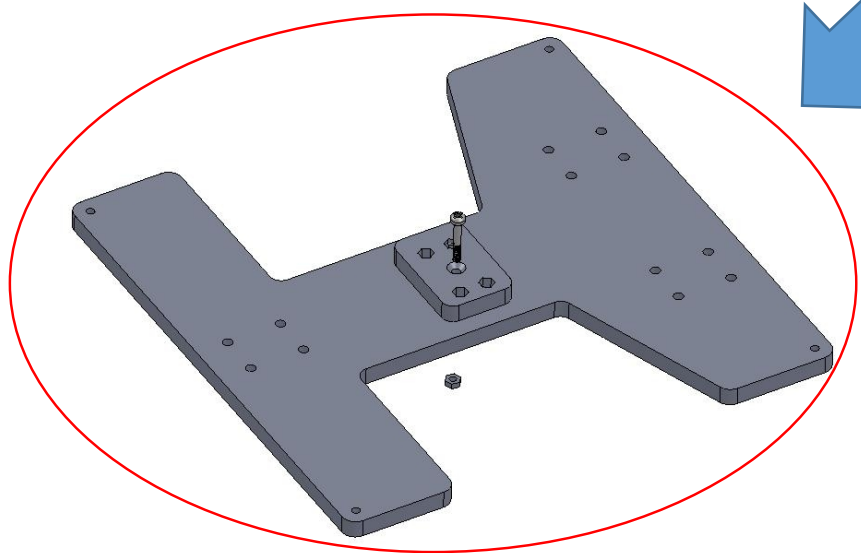
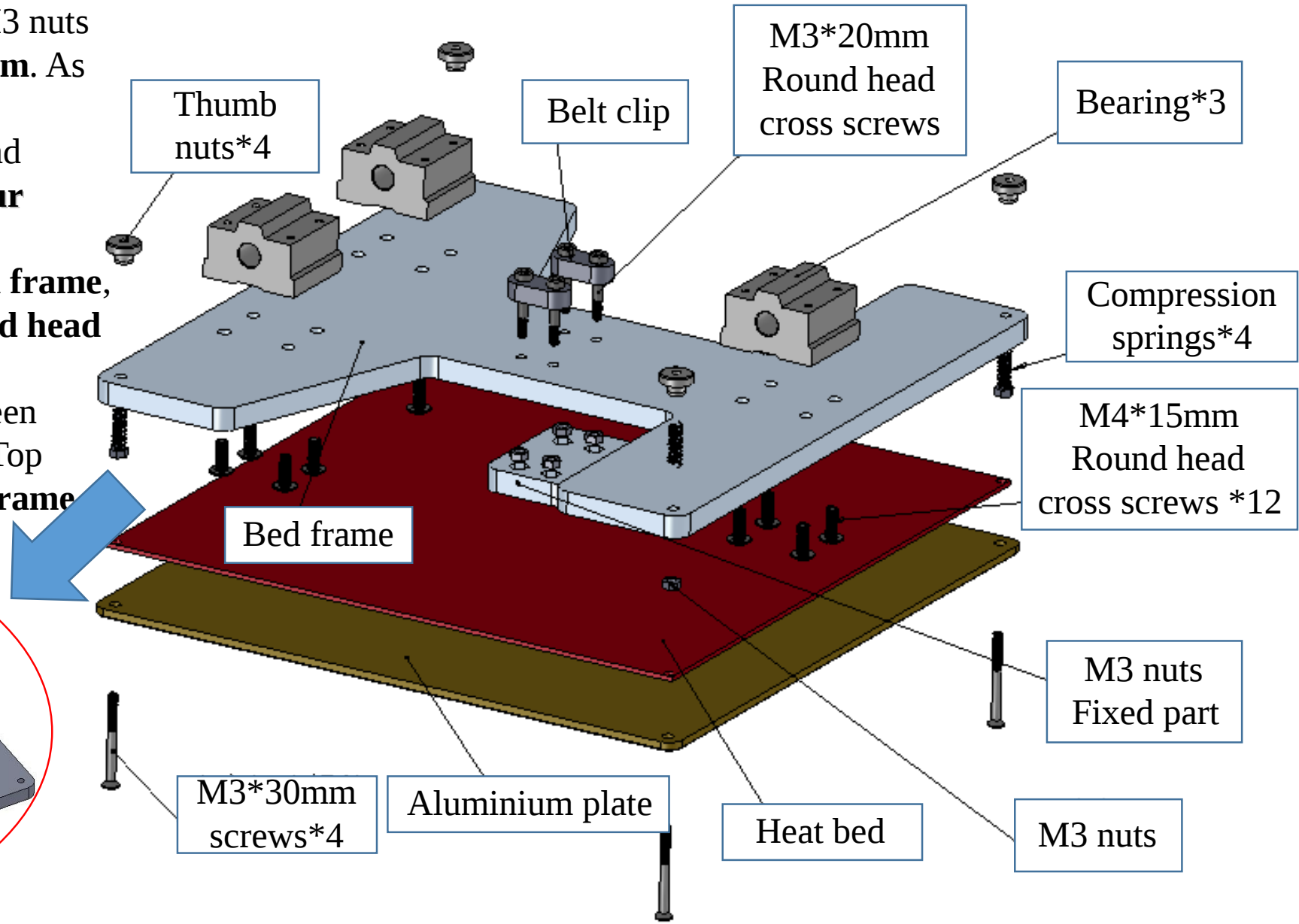

Step 6 Assemble Extruder (Standard EG-1)

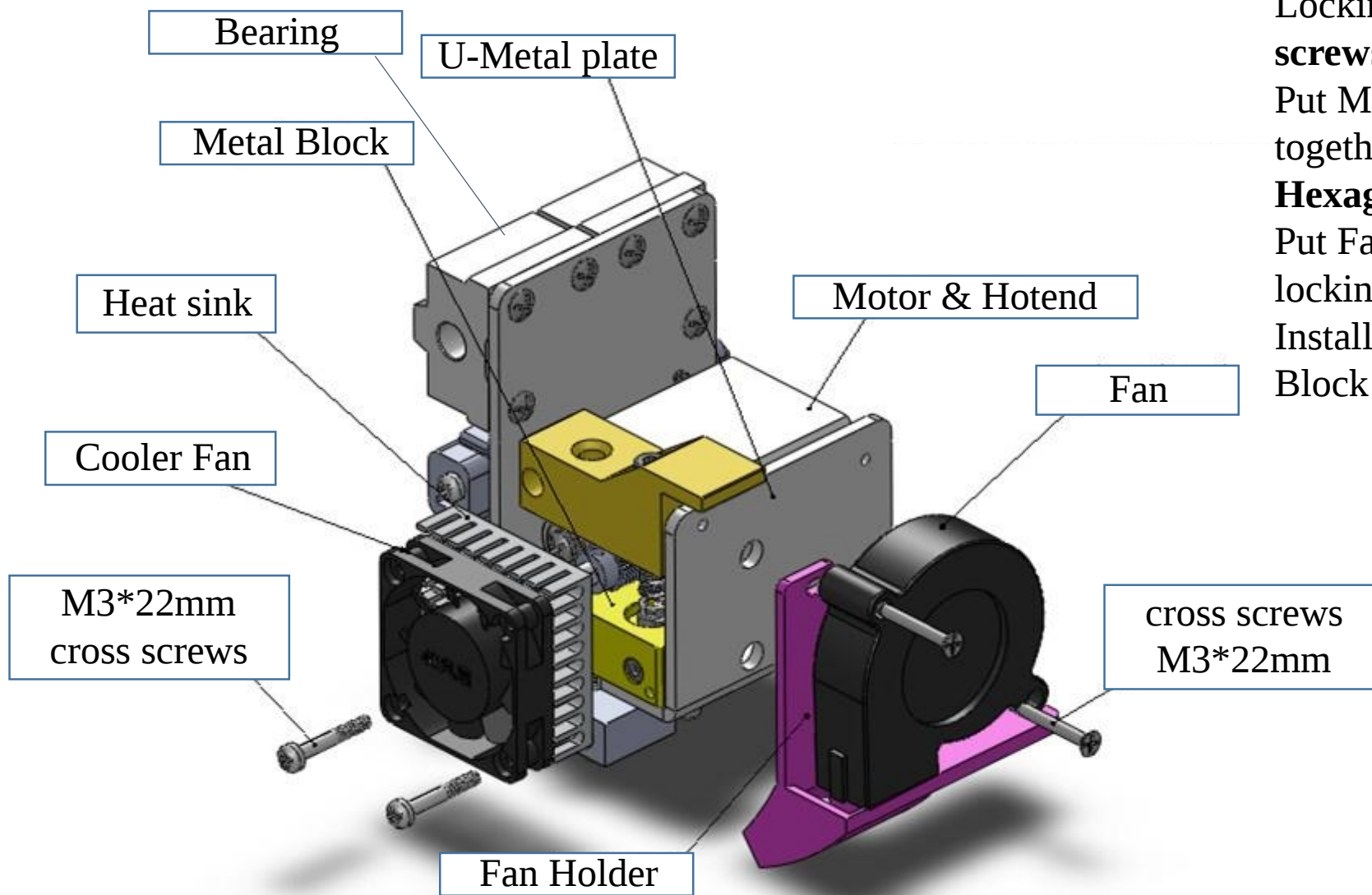

Install **3pcs Bearings** to the U-Metal Plate, Locking with **12pcs M4*8mm Round head Cross screws**.

Put Motor& Hotend module and U-Metal plate together , locking with **2pcs M3*10mm Inner Hexagon screws underneath**.

Put Fan and Fan Holder to the U-Metal plate, and locking with **2pcs M3*22mm Cross screws**
Install Cooler Fan and Heat sink on the Metal Block use **2pcs M3*22mm cross screws** .

Step 6 Assemble Extruder (with Auto leveling- EG-1+)

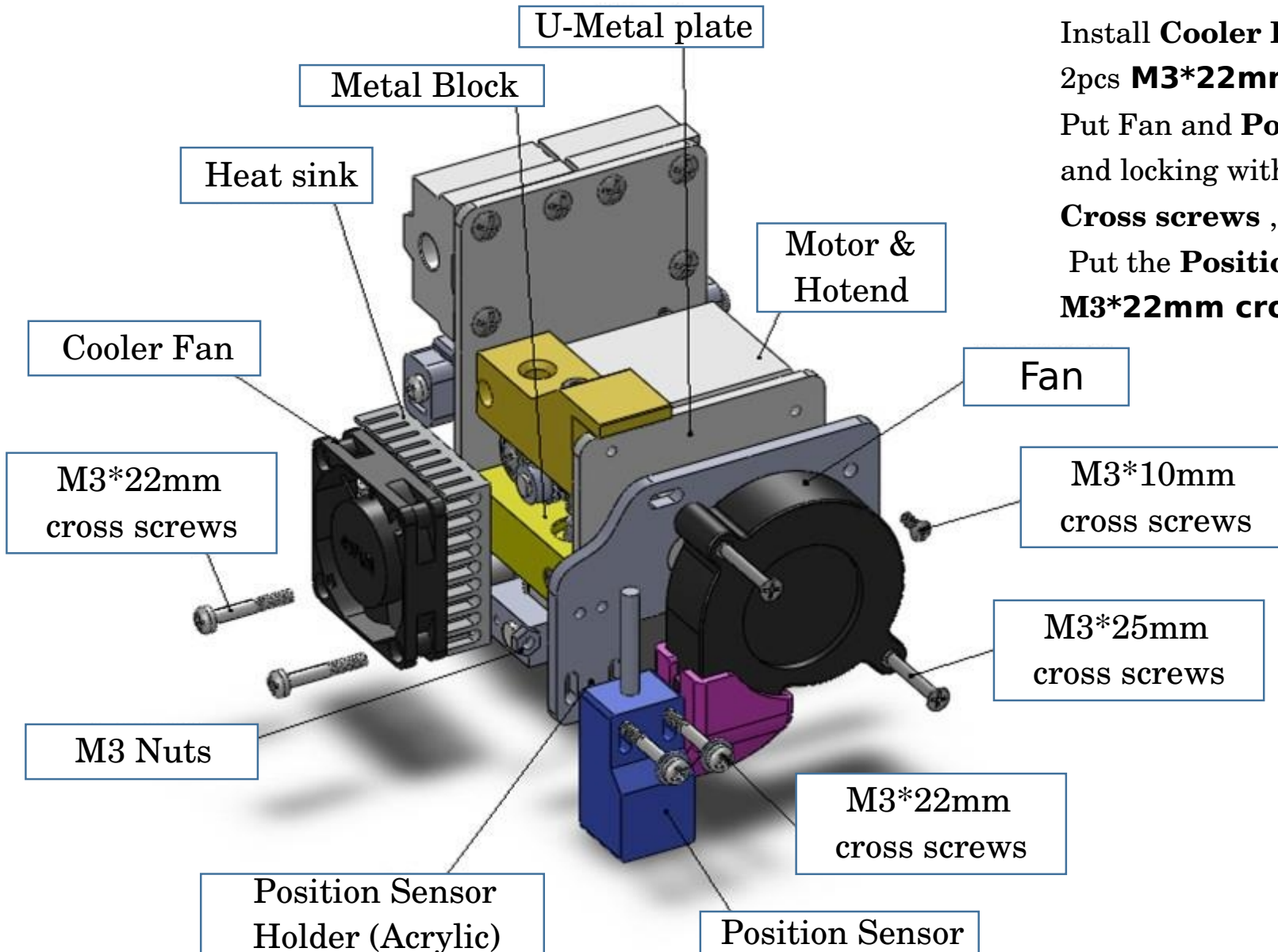

Install **Cooler Fan** and **Heat sink** on the **Metal Block** use 2pcs **M3*22mm cross screws** .

Put Fan and **Position Sensor Holder** to the **U-Metal plate**, and locking with 2pcs **M3*20mm** and 1pc **M3*10mm Cross screws** ,as picture

Put the **Position Sensor** on the holder ,locking with 2pcs **M3*22mm cross screws**.

Step 7 Assemble Z-axis motor

Put two **Z-axis motor support(side)** in two sides of the motor, Cover the **Z-axis motor support(top)** on the top, locking with **M3*20mm Round head screws & nuts**.

The cable of Z-axis motor is back of the Z-axis motor support. Locking **Z-axis motor** with four **M3*10mm Inner hexagon screws**.

Put the **coupling** on the motor, locking with the jackscrews.

The other Z-axis motor is the same assembly.

Note : that the two z axis motor supports (top part) are identical and symetric.

Make sure you end up with the small round hole on the left for the left motor holder and on the right for the right motor holder. The picture presents the right motor.

Do not install the motors immediatly.

Wait until step 9. It will be easier to perform.

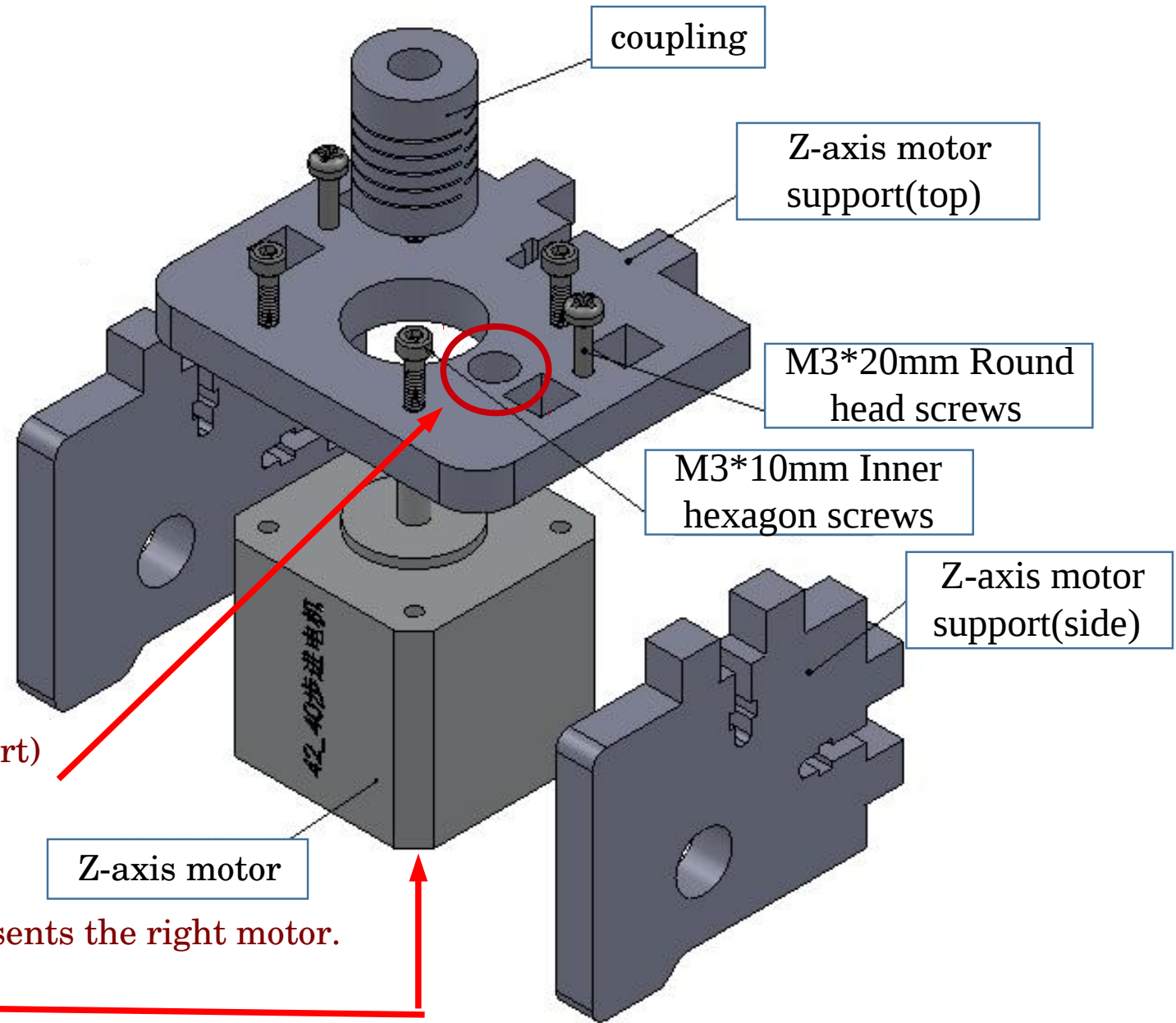

Step 8 Assemble Z-axis

As shown, Put the two **Z-axis motors assembly** on the left and right side of the **Bottom plate**, locking with three **M3*20mm screws & nuts**.

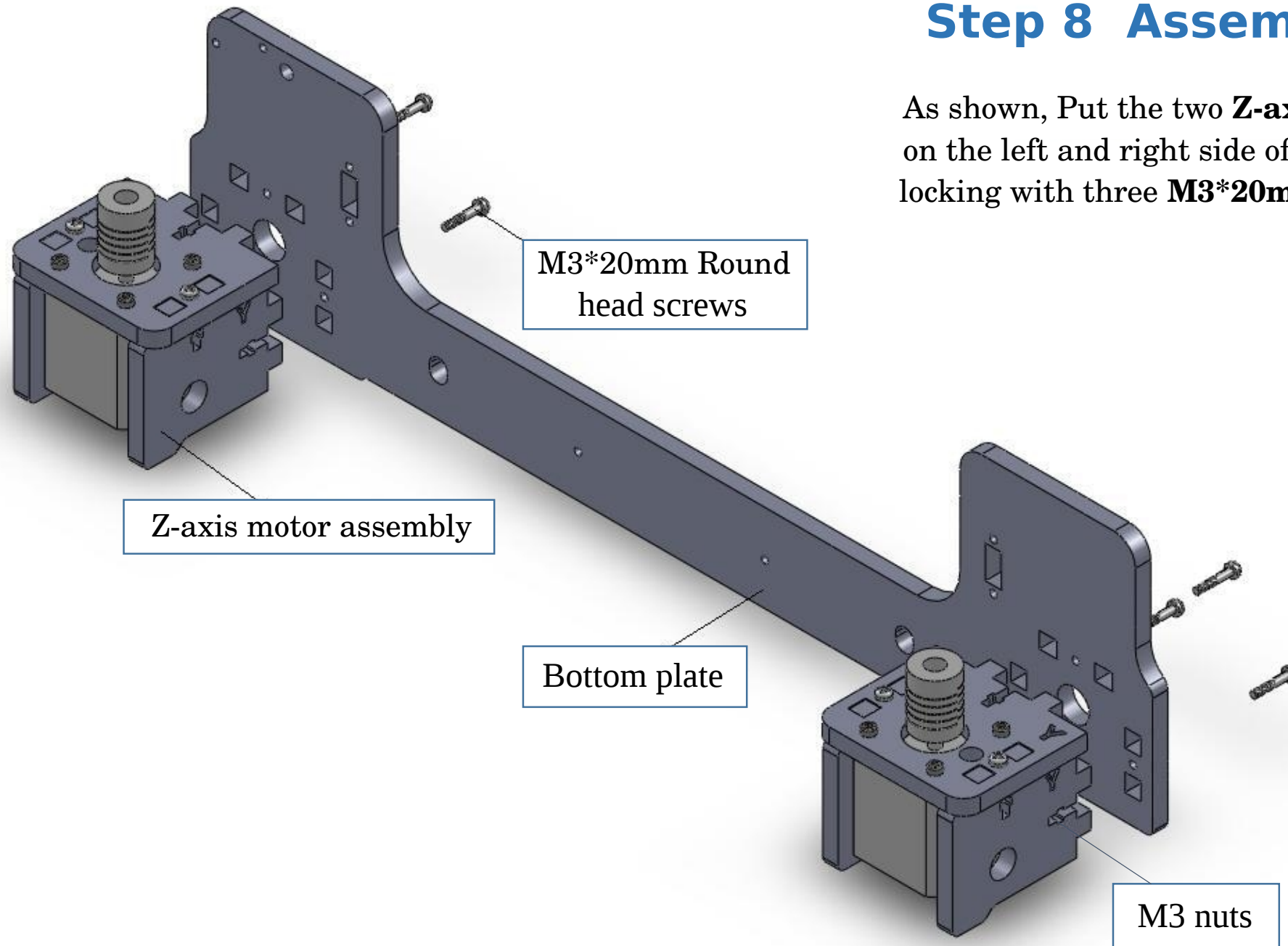

Step 9 Assemble Side plate

As shown, Put the two **Side plate** on the left and right side of the **Bottom plate** , locking with four **M3*20mm screws & nuts**.

NOTE :

Once you have secured the z axis motor holder to the frame, you can install the motors.

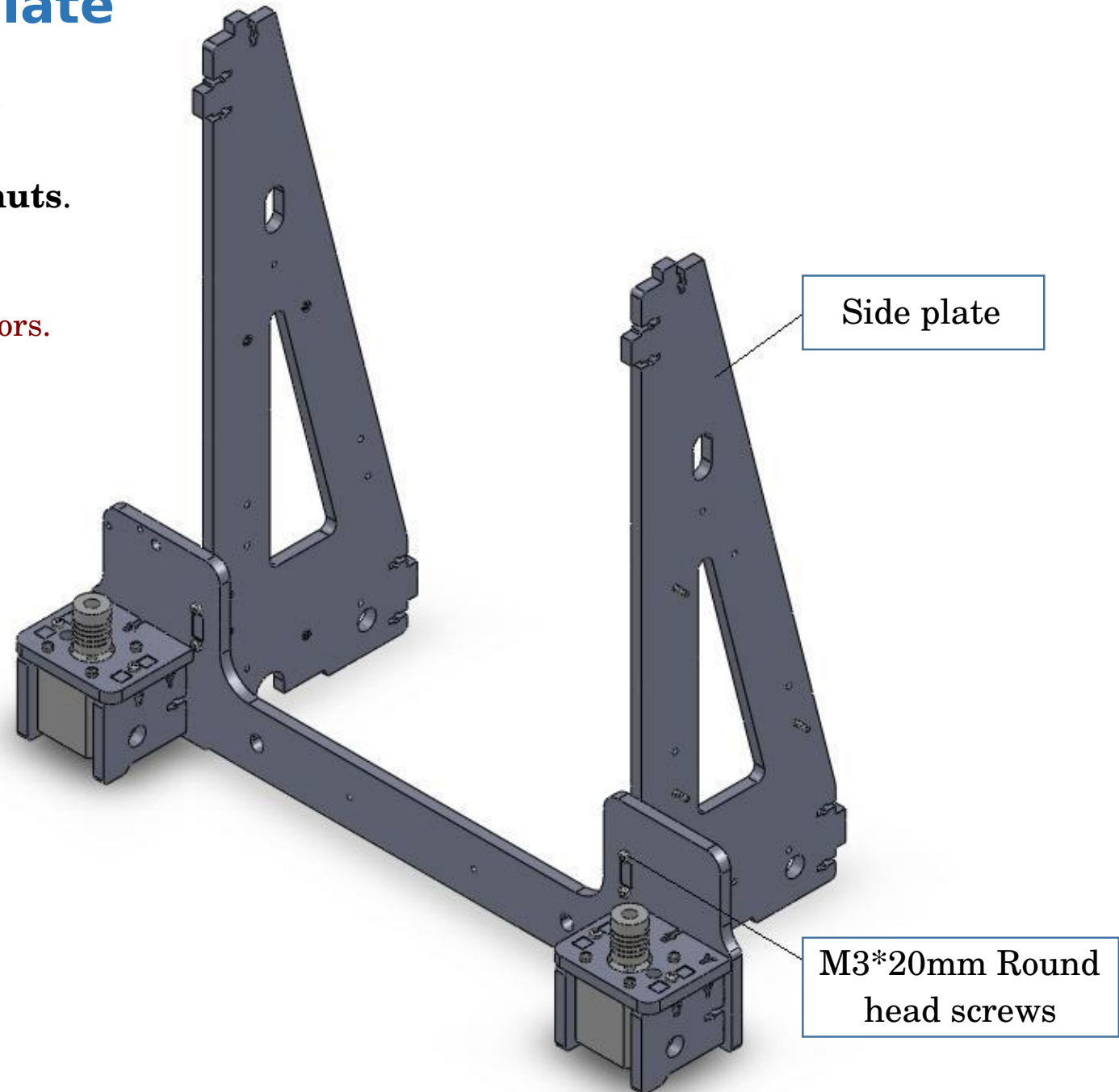

Step 10 Assemble Top plate & Junction Plate

As shown, put the **Top plate** on **Side Plate**, locking with four **M3*20mm screws & nuts**.

Put the two **Junction Plate** on the top of the **Side plate**, locking with four **M3*20 screws & nuts**.

Put two **sliding rod restriction** on the top of left and right sides. Locking with one **M3*20mm Round head screw & nut** each.

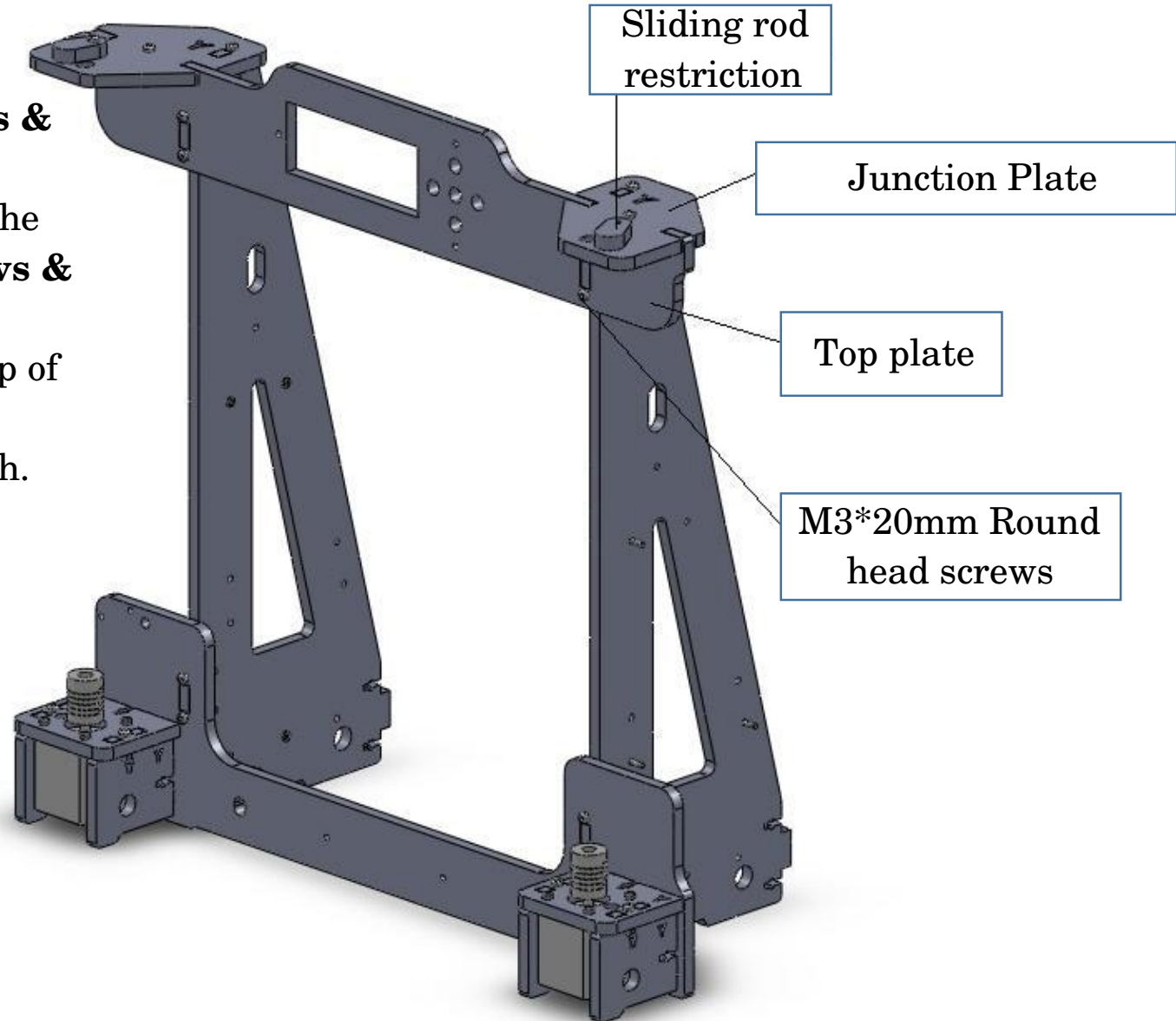

Step 11 Install LCD display

Put the **LCD display** on the top of the **Top plate** ,locking with three **M3*25mm flat_head screws &nuts**

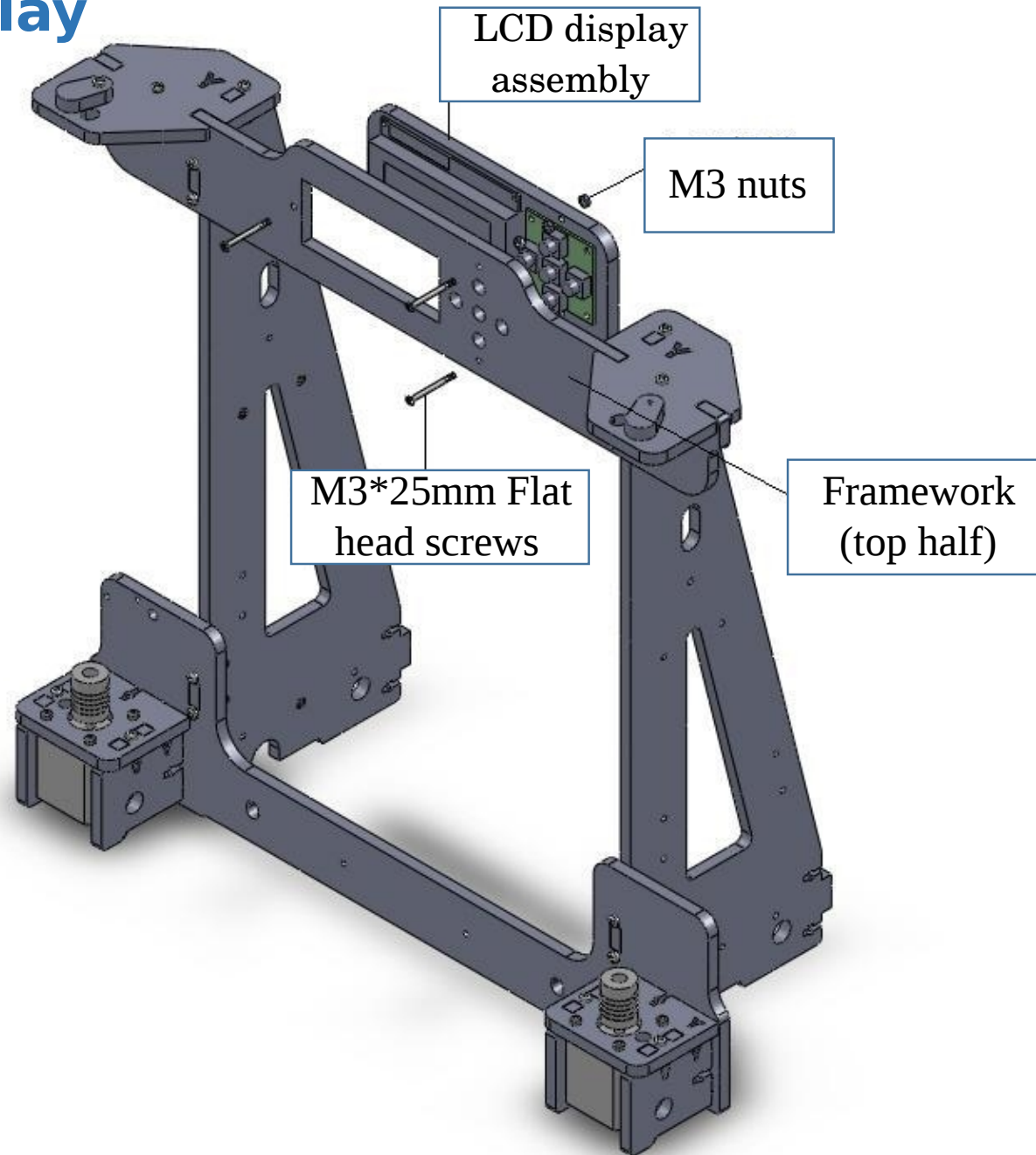

Step 12 Install Z-axis Limit switch

Put the **Z-axis limit switch** on the left side of **Bottom plate**, Locking with two **M3*20mm Round head screws and nuts**.

This switch will not be in the kit for this model the EG-2. It is replaced by the capacitive proximity sensor! See step 6.

M3*20mm
Round head
screw & nut

Z-axis limit
switch

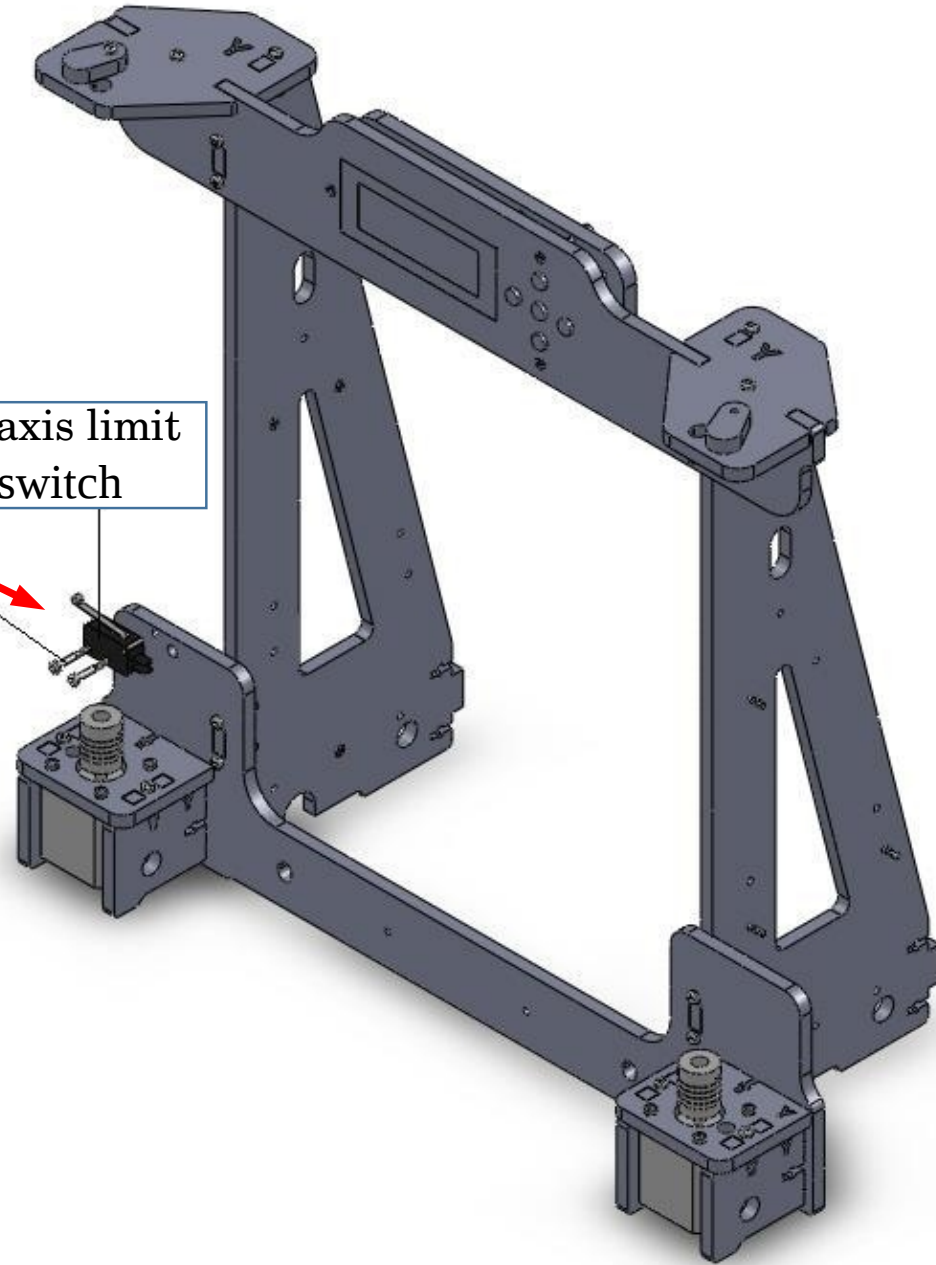

Step 13 Install Power supply

Put **Power supply** on the right of the **side plate** , locking with three **M3*14mm Flat_head screws and nuts**.

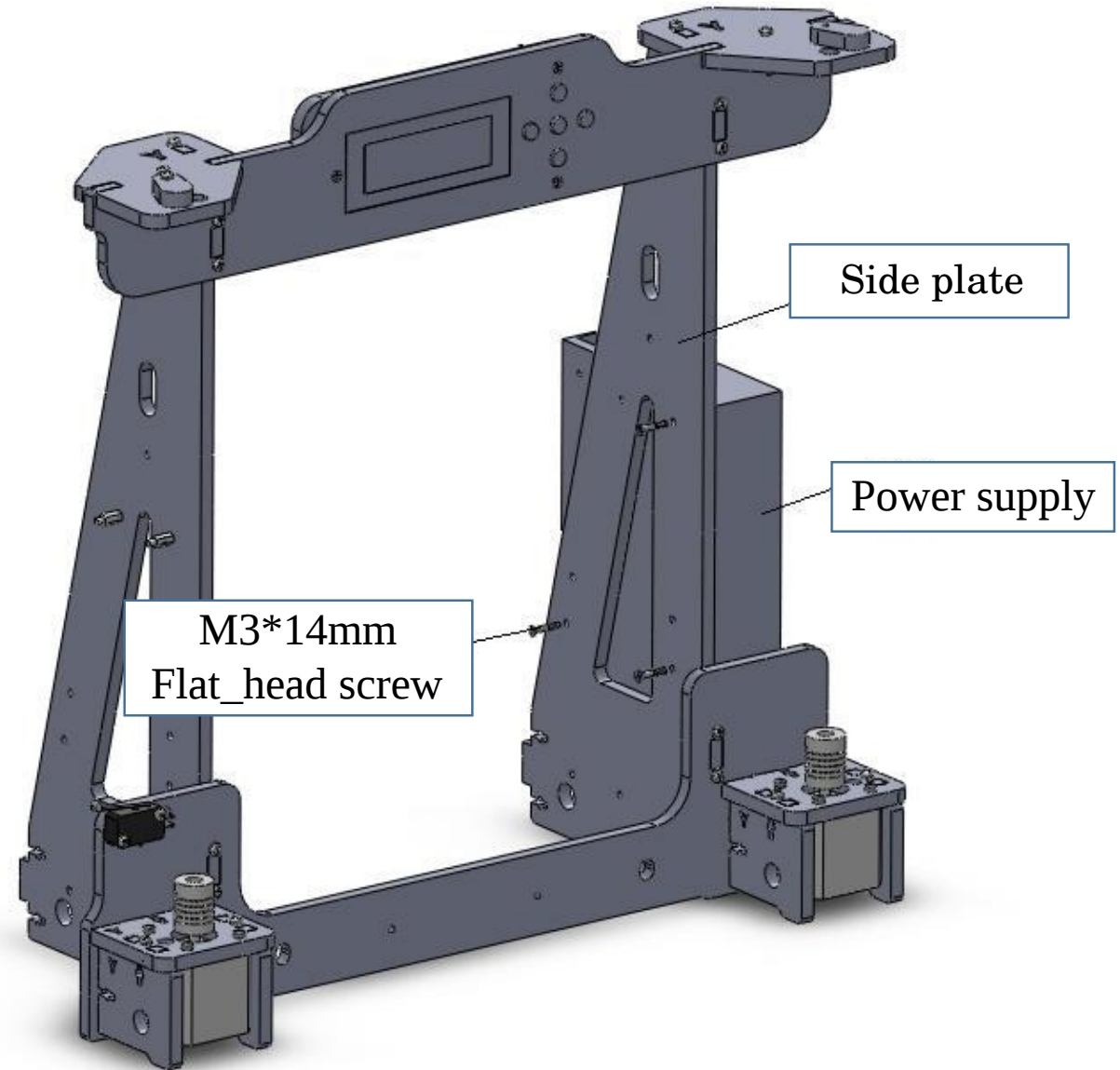

Step 14 Install PCBA Control Board

Install **Control Board** as picture , locking with **Four M3*30mm Flat head screws + 4pcs Plastic pillars + 4pcs M3 nuts**

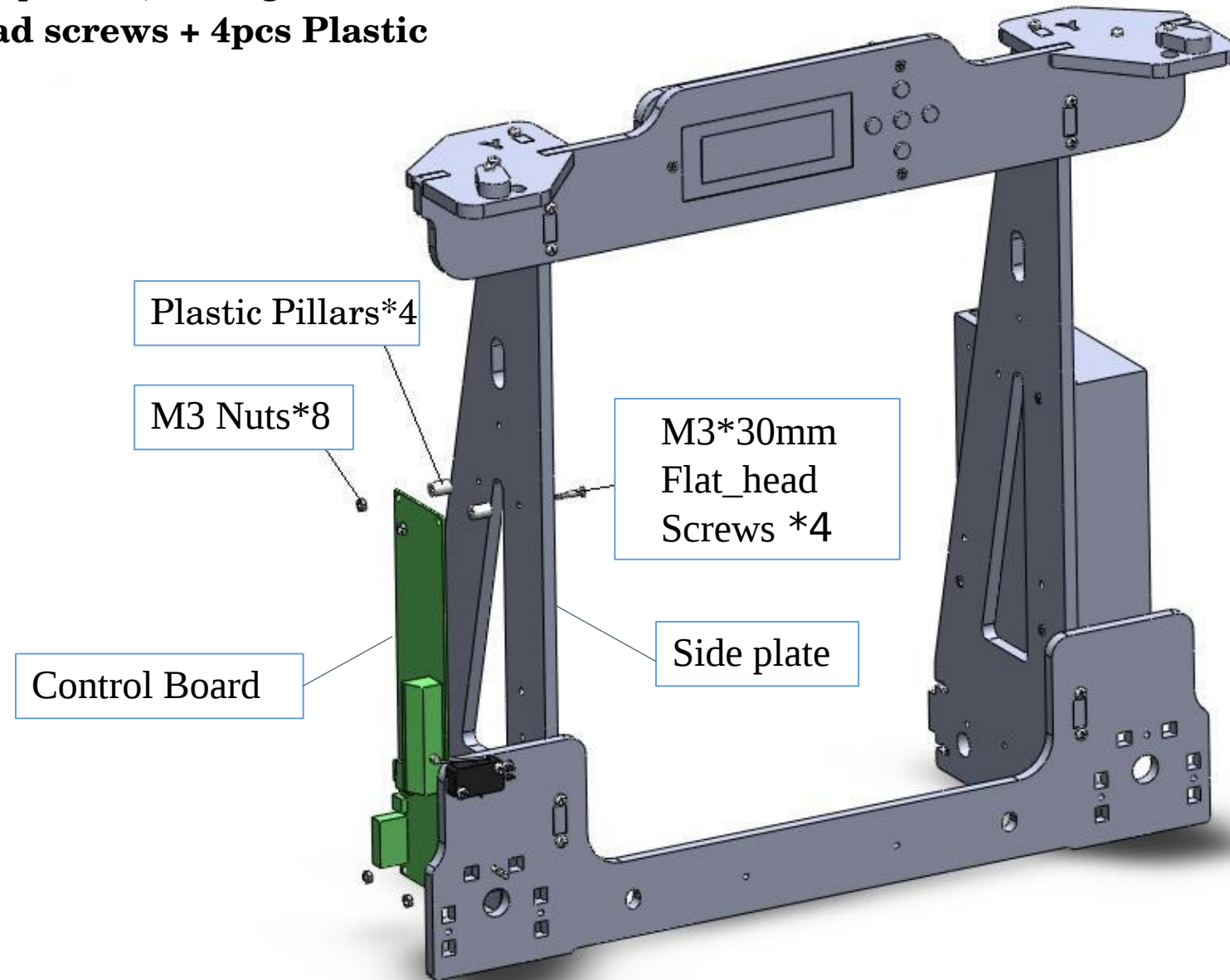

Step 15 Install Base frame holder_Back

Put the **Base frame holder_back** back of **Side plate**, locking with four **M3*20mm Round head screw**

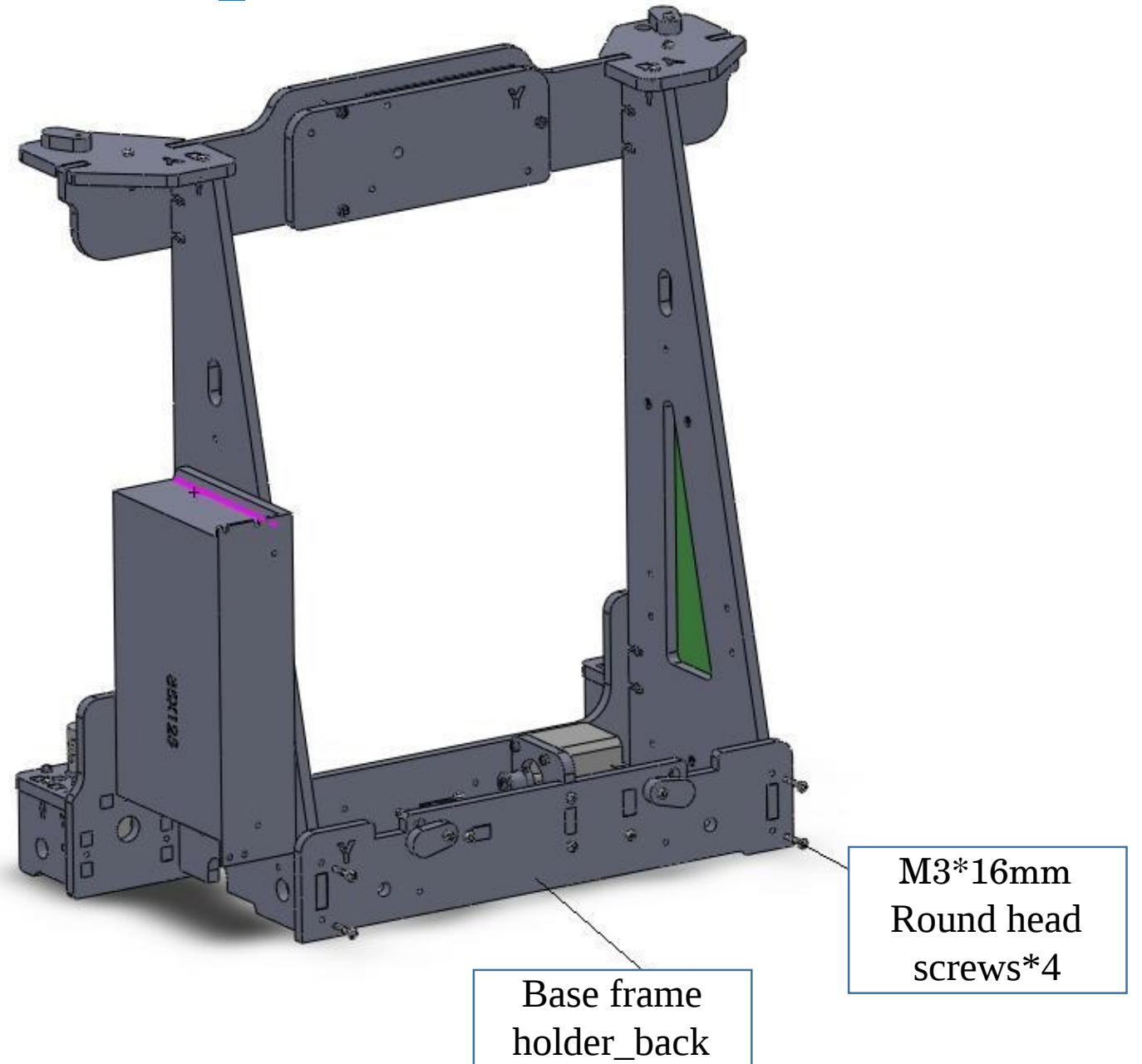

Step 16 Install Base Frame Holder_Front

Through the **Frame Holder_Front & Back** by two **M8*400mm screw arbors**, locking with twelve M8 Nuts & cushion ring.

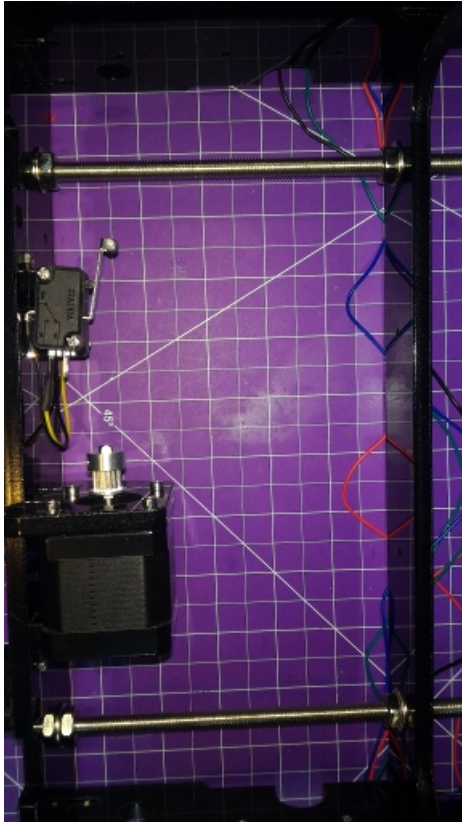

A better view of the screws layout

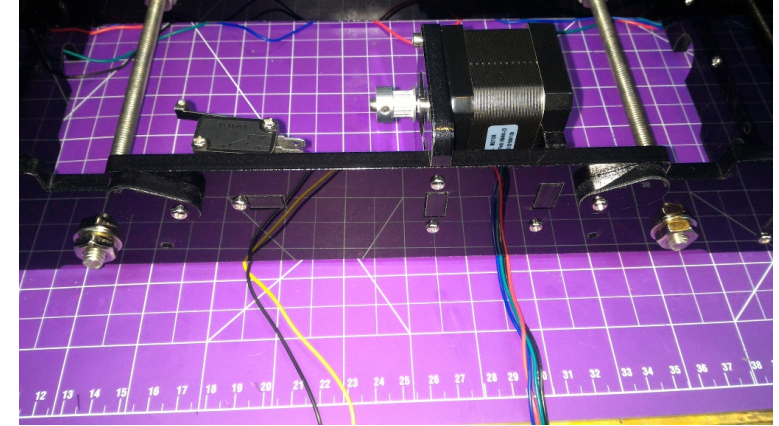
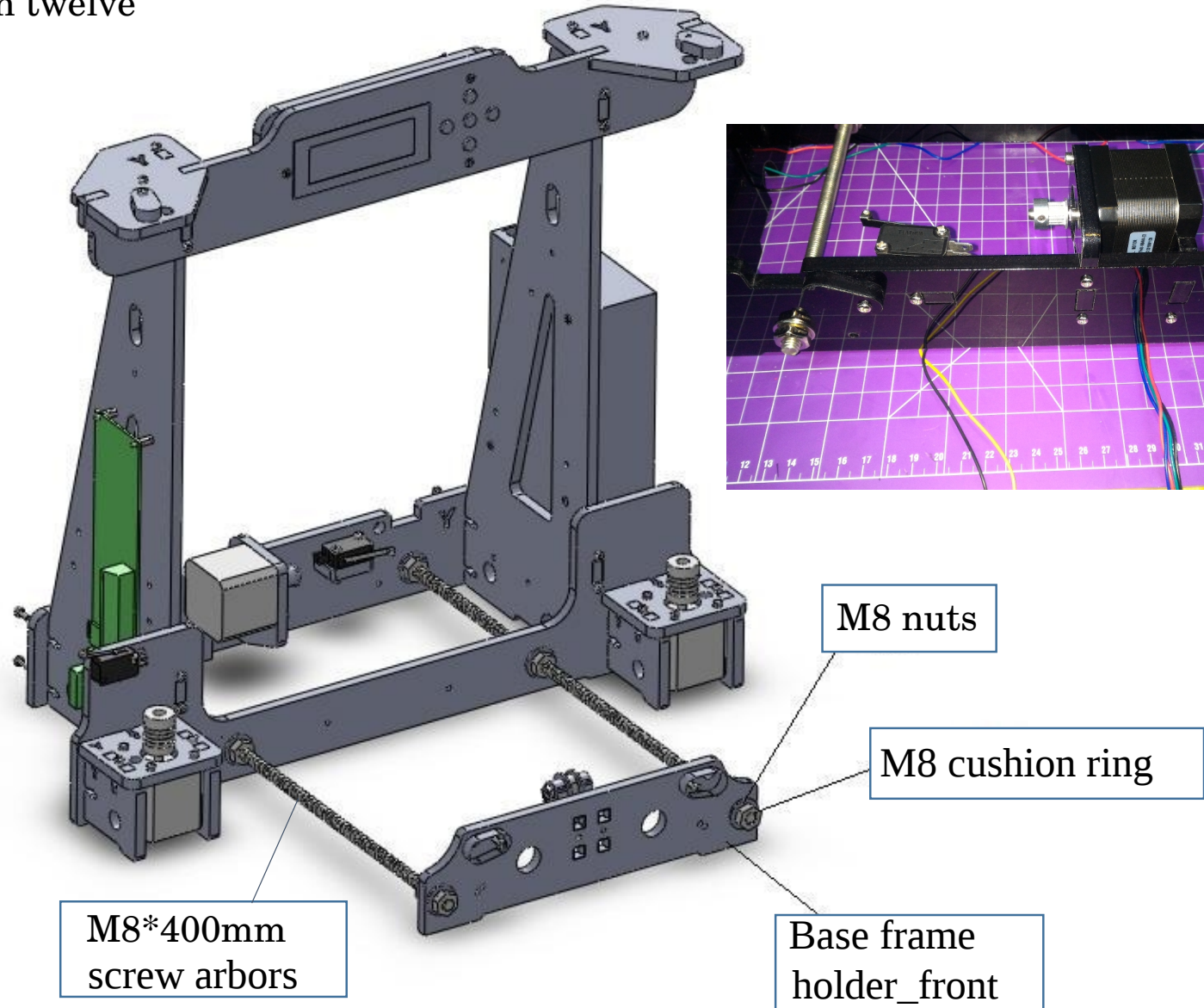

Step 16-B Measure the distances

Before tightening the 8MM bolts, measure the distance from the frame to the front plate. Should be between 220mm and 230mm.

You might need to readjust later, after the Y carriage is installed.



Roughly 220 to 230mm.
Don't overtight
Yet!!!

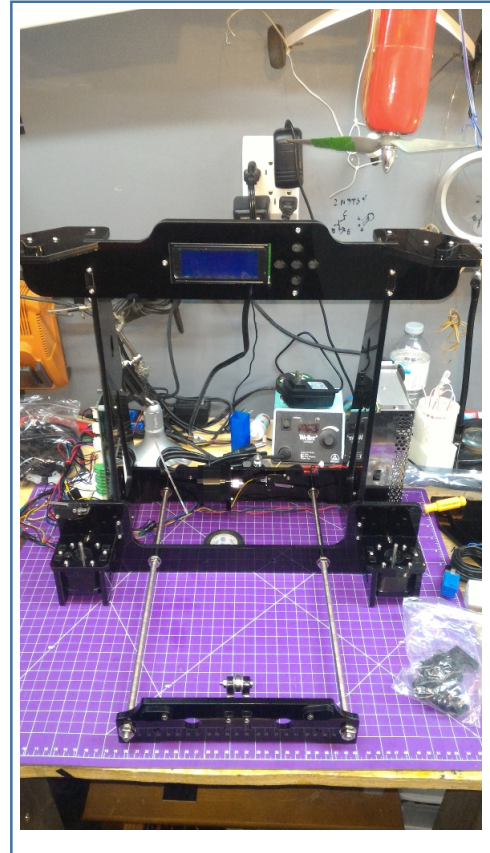

Frame mounted and
Square by measure

Step 17 Instal Platform Assembly

As shown , through the platform on the base by two of **M8*380mm Sliding rod**.
Fix both end by Sliding rod restriction

Attention: Put the 1pcs bearing on the hotbed on the left side , and put the hotbed wires on back side .

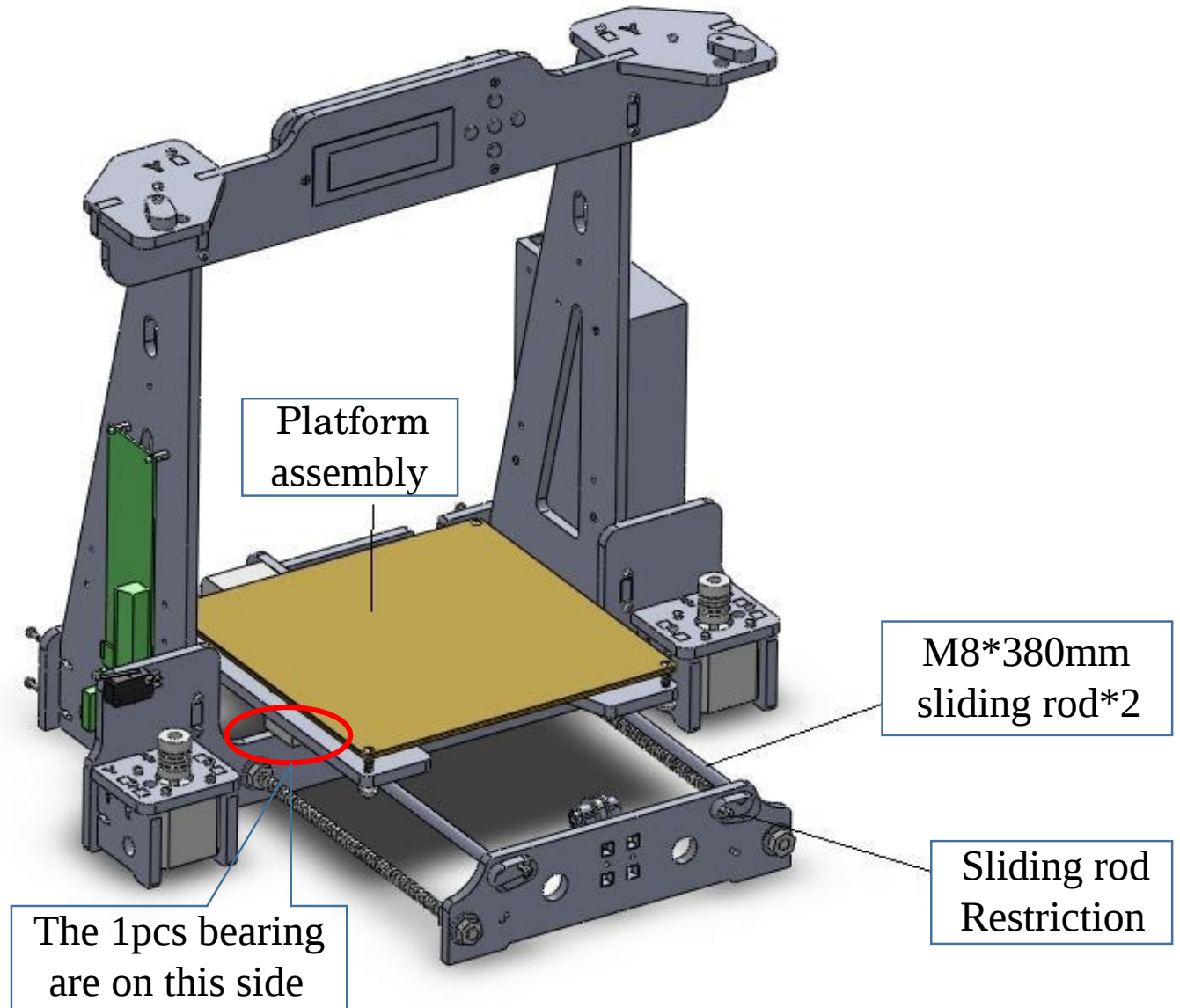

Step 18 Instal Y-axis Timing belt

As shown, Lock one end of the timing belt in belt clip , the other end through the Y-axis motor and belt pulley wheel on the base frame holder. Then tense the belt and lock in the other belt clip with **M3*20mm Round head screws & nuts**.

Once the belt clips are tight, tight the screws of the pulley holder to increase the belt tension as needed.

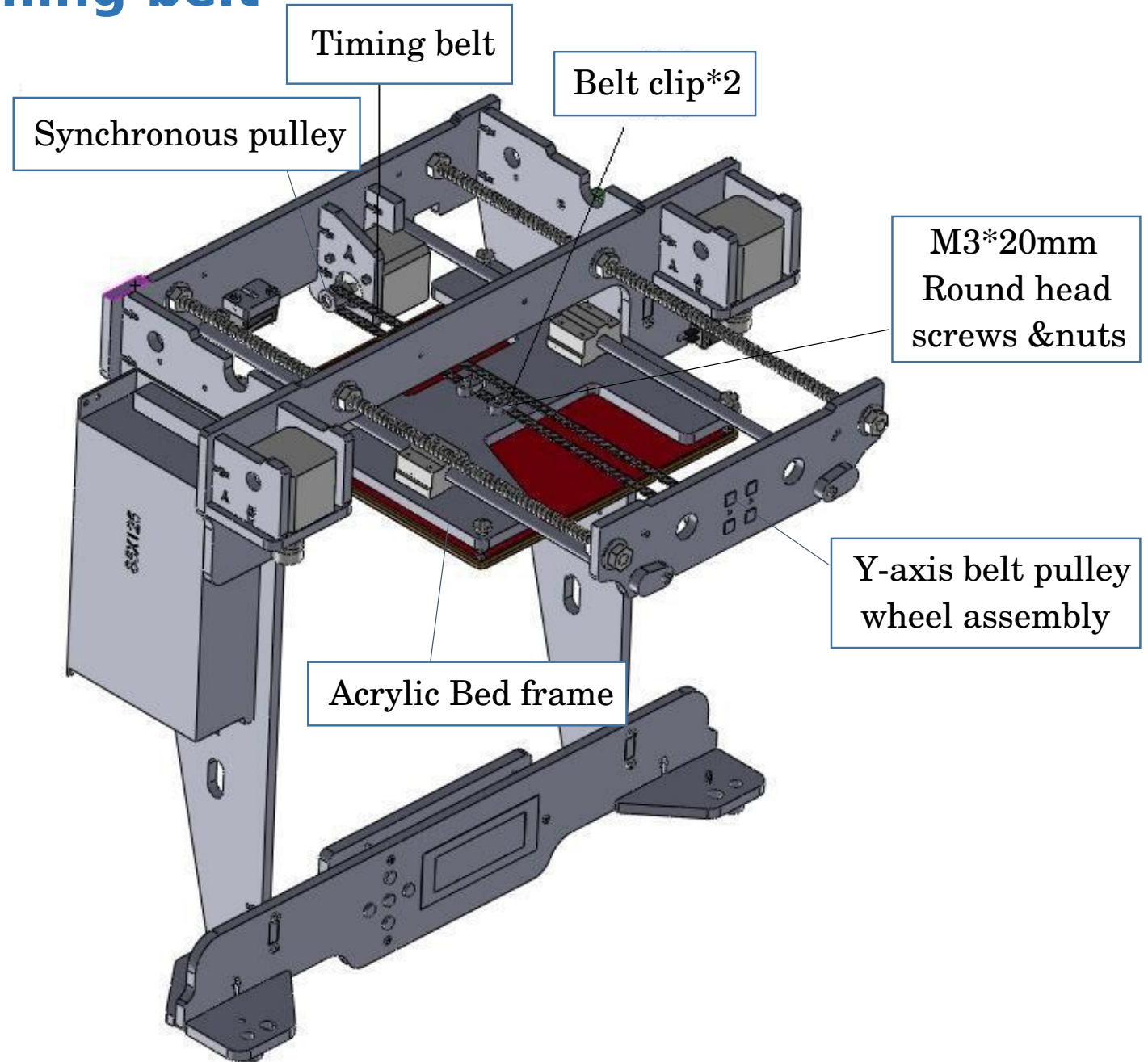

Step 19 Instal X-axis Motor & Pulley mount

Put **X-axis motor** on **X-axis motor mount**.
Locking with three **M3*10mm Inner hexagon screws**.

Through the **X-axis motor mount & pulley mount** by **M8*380mm sliding rod & M8*345mm screw arbor**. As picture

Limit the top of **sliding rod** with **sliding rod restriction**, connect the bottom of **screw arbors** with **couplings**, locking jackscrew in coupling.

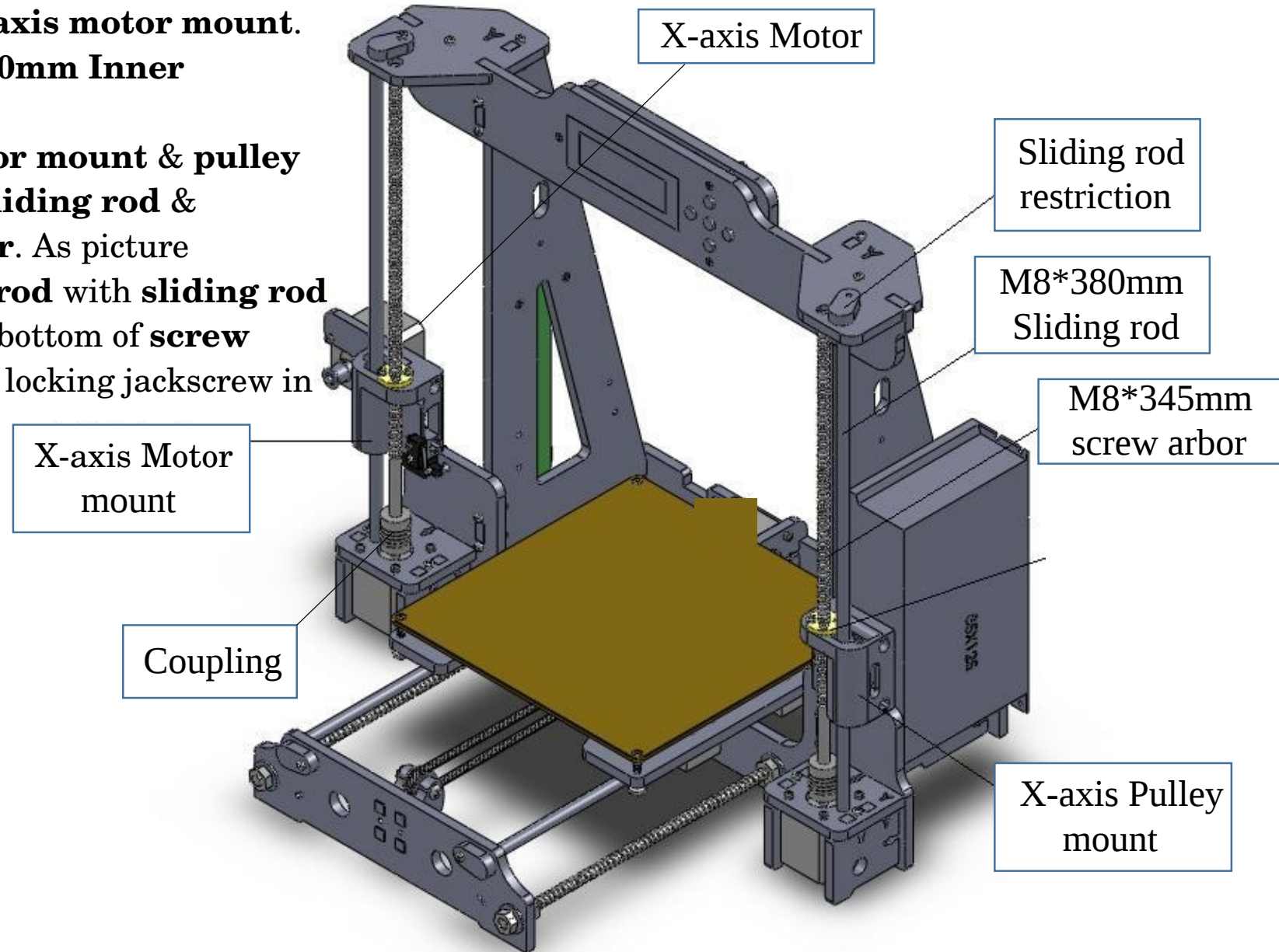

Step 20 Assemble X-axis

Through the X-axis **motor mount** & **Pulley mount** and **Extruder assembly** using two **M8*443mm sliding rods**, as the picture.

Put **X-axis limit switch** on the X-axis motor mount, locking with two **M2.5*10mm screws** (small black screw)

NOTE :

The X axis limit switch must be installed with the metal roller pointing down.

If the switch is installed upside down, it won't make contact with the extruder carriage.

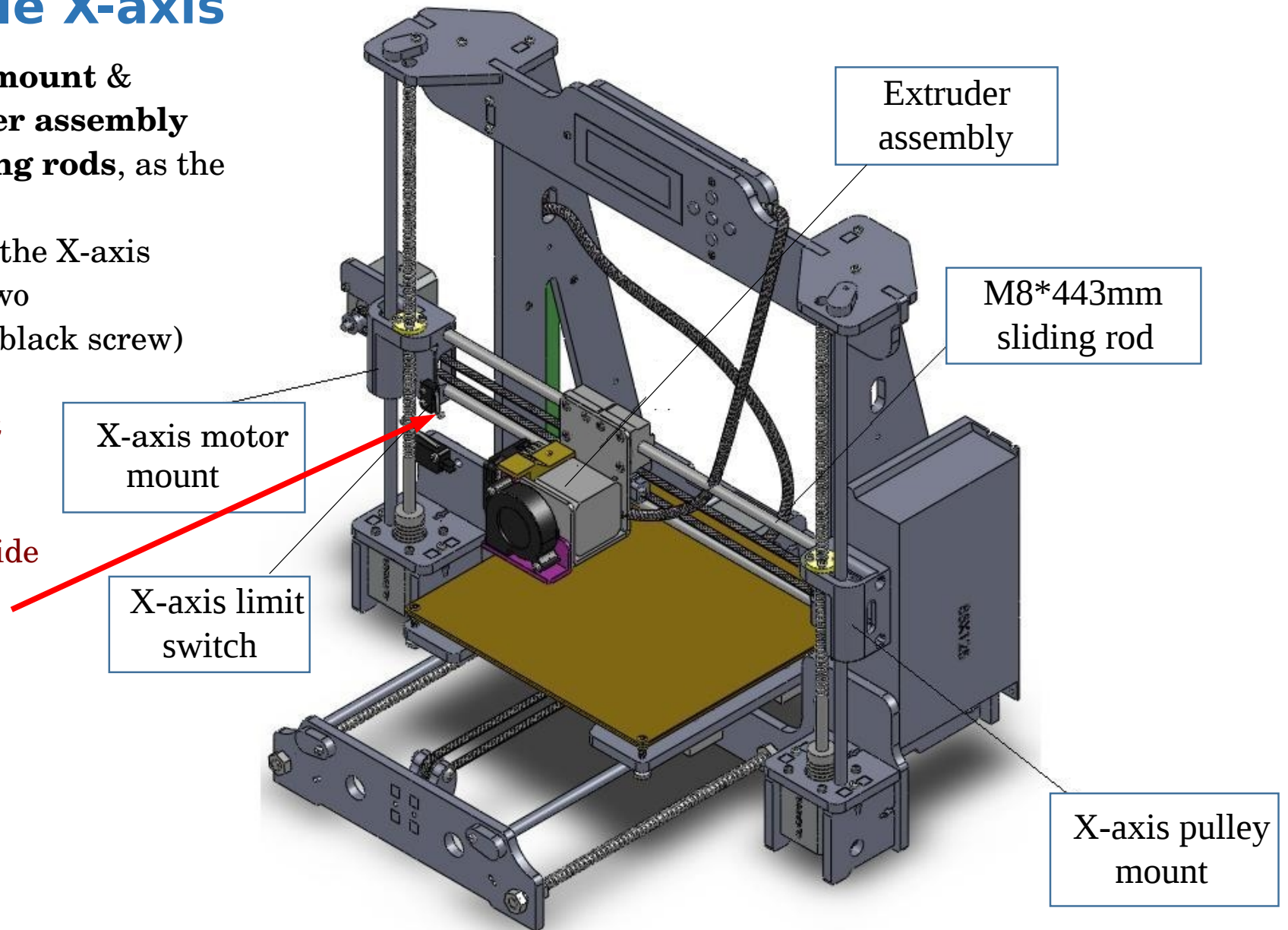

Step 21 Instal X-axis Timing Belt

Tighten one end of the **Timing Belt** to the **Belt clip** with **Nylon cable ties**. The other end through the X-axis pulley & motor ,then tighten another end of the belt to the another **Belt clip** with **Nylon cable ties** . as picture below

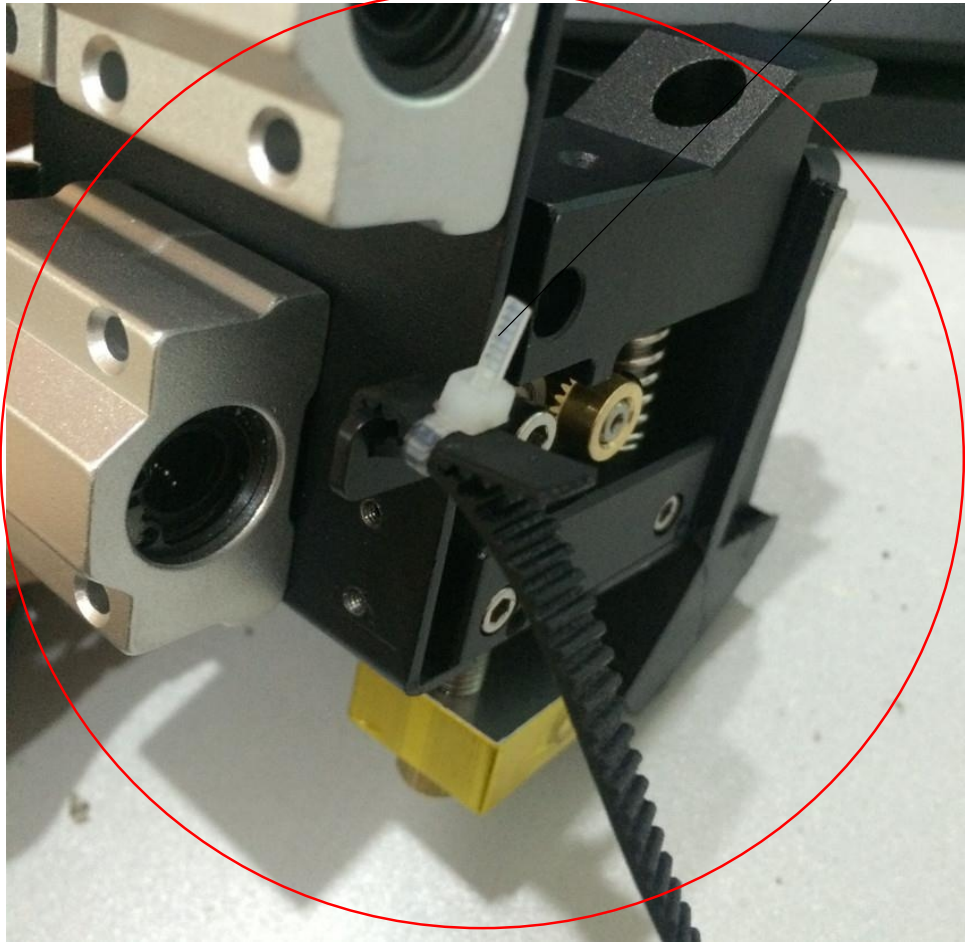

Nylon cable ties

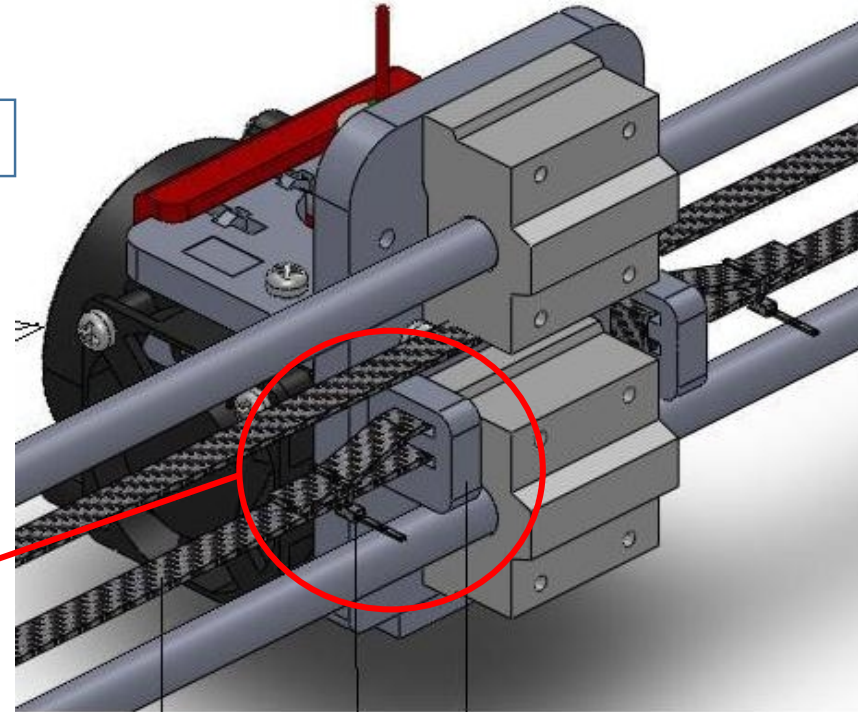

X-axis timing belt

Nylon cable ties

Belt clip

Step 22 Control Board Wiring Diagram

The method of connecting wire is as picture

!NOTE!: The wires connected to POWER SUPPLY and HETBED must be AWG14 or thicker one.

Wire the X Y Z axis Limit switches "COM" and "NO" these 2 ends , as pictures

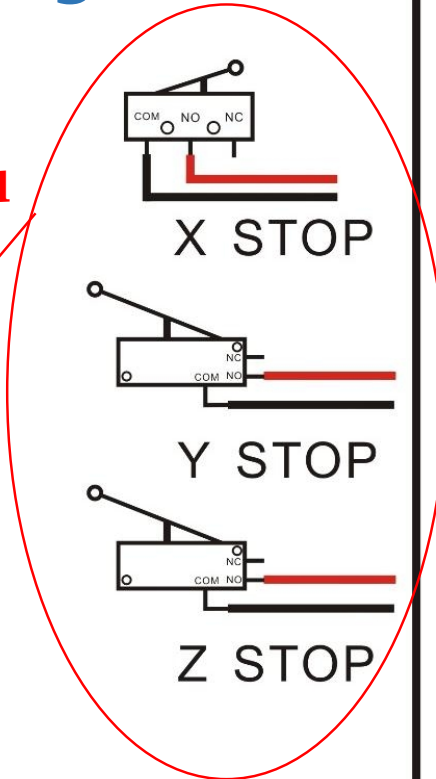

The red wire above

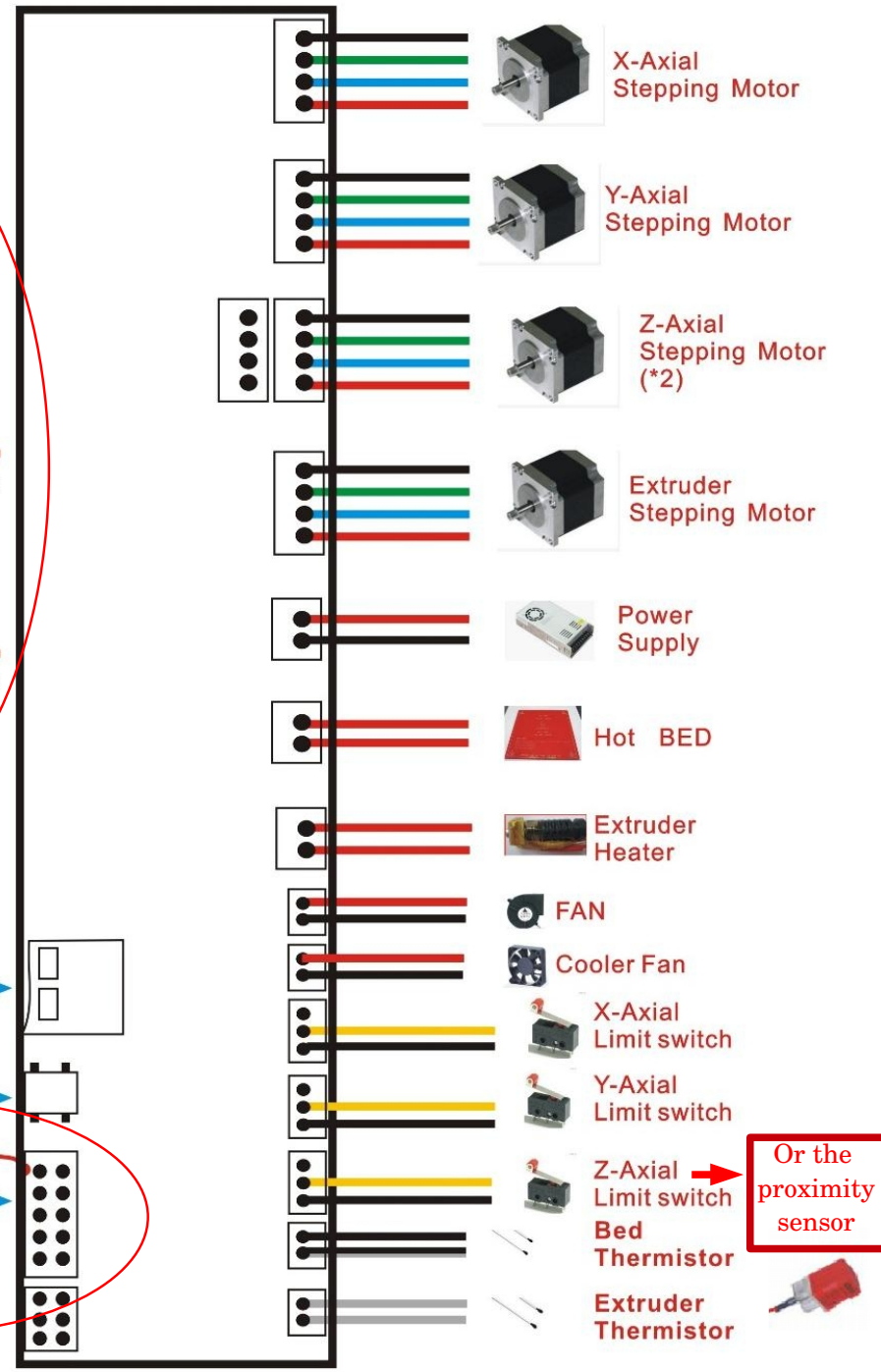
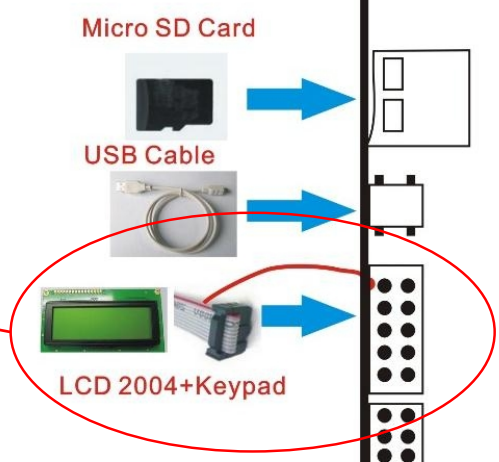
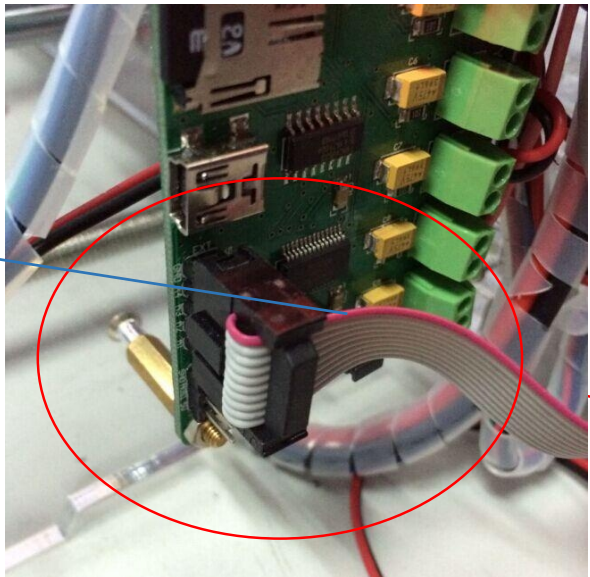

Step 23 AC Power Connector Wiri

Connect Power cable As shown (Right)

Note: There are different voltages in different country. Please select the appropriate voltage by switch before power on. As shown below.

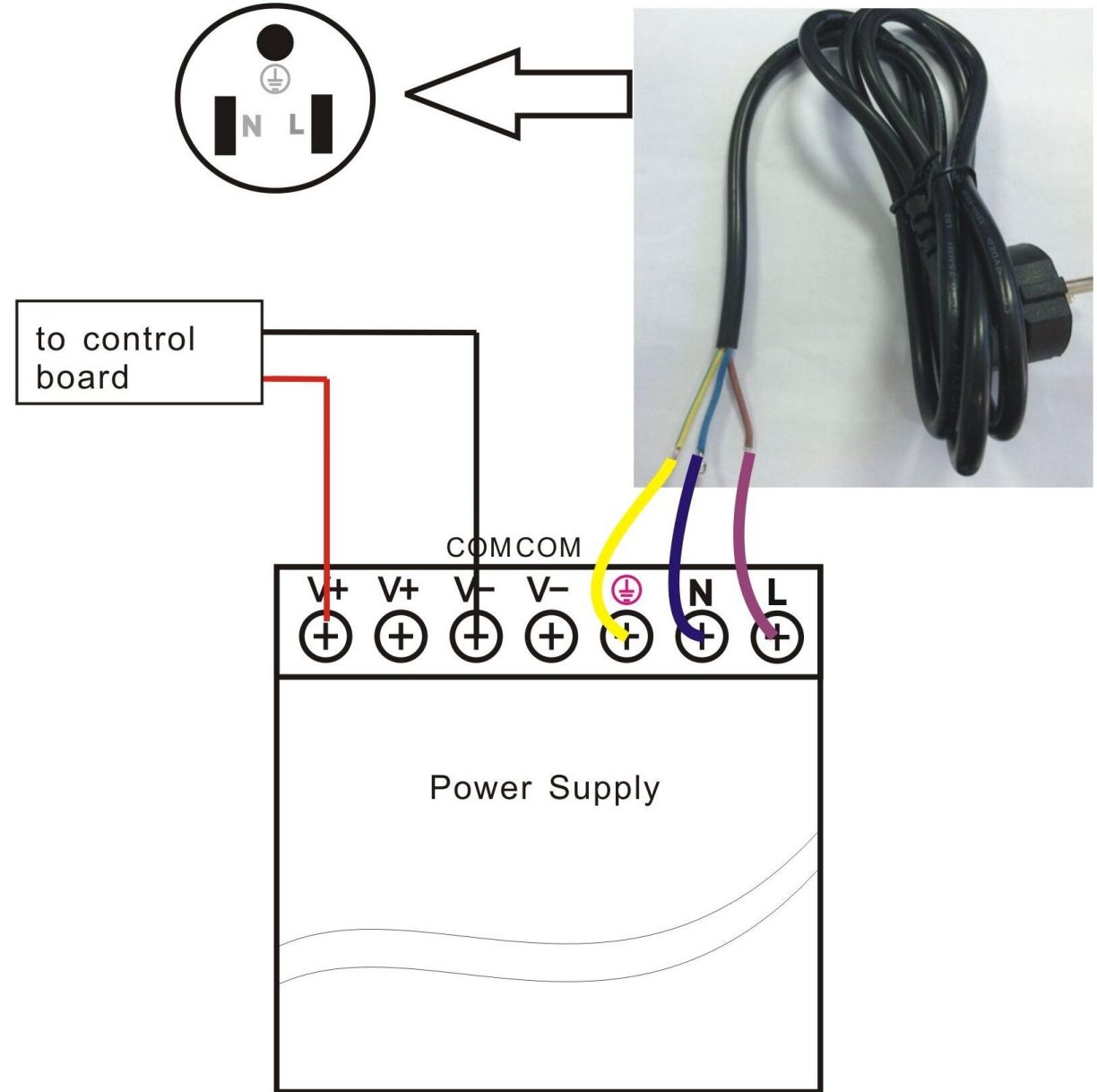

Step 24 Assemble Filament Feeder

Separately put two **Steel Pipe holder** on two **Filament support frame**, locking with four **M3*20mm Round head screws & nuts**.

Connect the two **Filament support frames** with two **Fixed links**, locking with four **M3*20mm Round head screws & nuts**

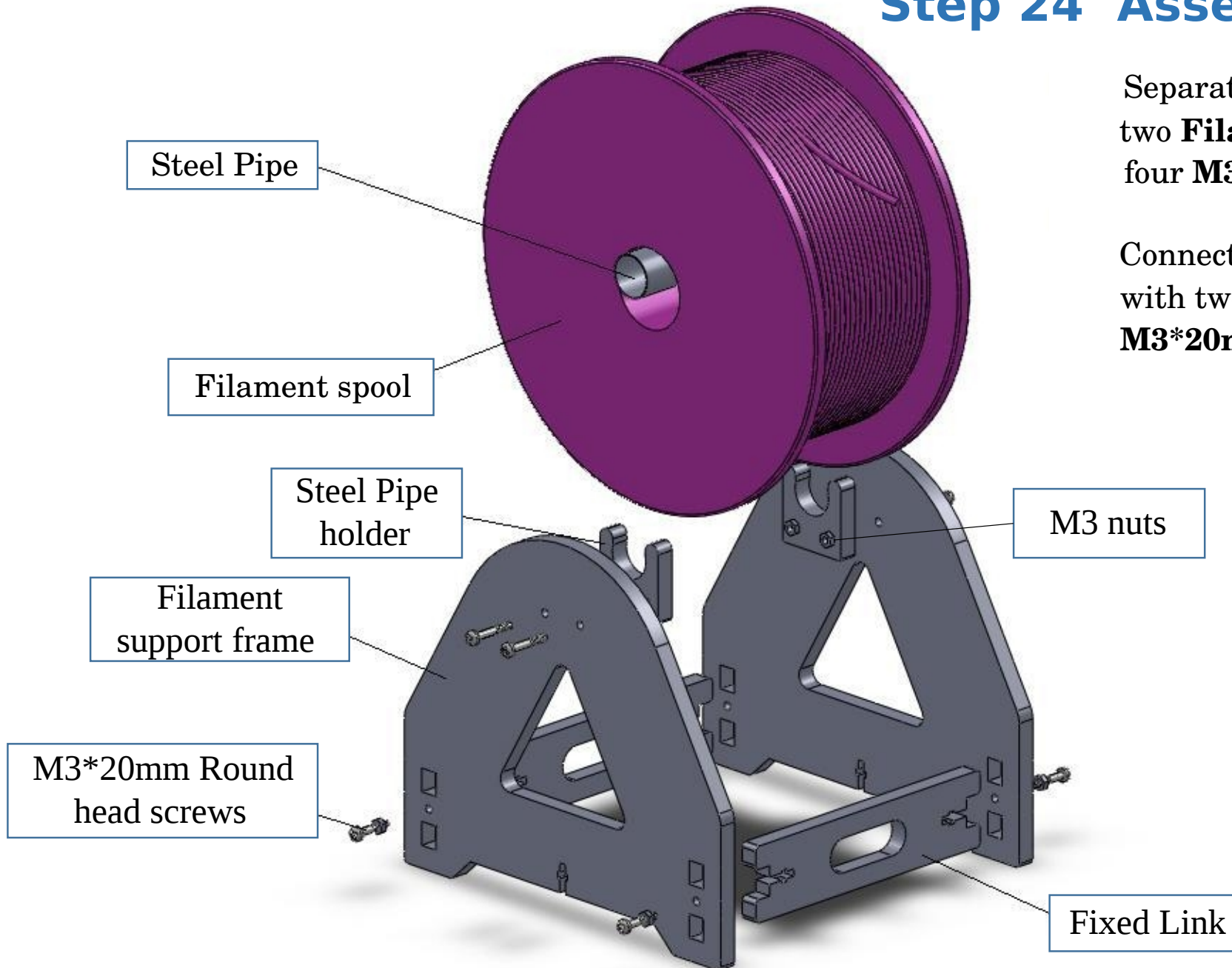

Installation Finished

